

L590-66-60

Epoxy Lens Type Yellow Color Illuminator

L590-66-60 is a wide viewing and extremely high output power illuminator assembled with a total of 60 high efficiency InGaAlP diode chips, mounted on a metal stem TO-66 with AlN ceramics and covered with double coated clear silicone and epoxy resin. These devices are designed for high current operation with proper heat sinking to improve thermal conductive efficiency.

<Features>

- High Reliability
- Compact(TO-66) Package
- High Output Power at 590nm

<Application>

- For High Intensity Lighting Source

<Specifications>

1. Product Name: Yellow Color Illuminator
2. Type Number: L590-66-60
3. Chip:
 - Chip material: InGaAlP
 - Peak Wavelength: 590nm typ.
4. Package
 - Type: TO-66 Stem with AlN
 - Lens: Clear Epoxy Lens

Outer Dimension (Unit:mm)

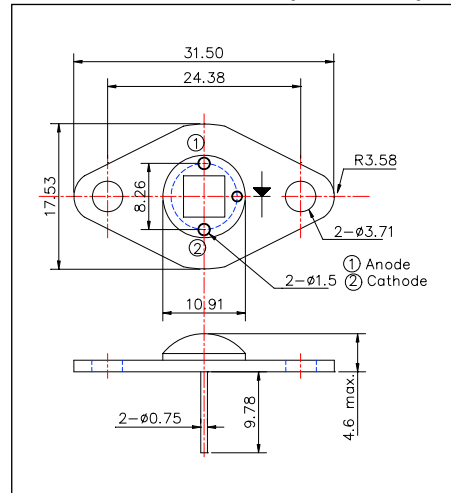

Absolute Maximum Ratings[Ta=25°C]			
Item	Symbol	Maximum Rated Value	Unit
Power Dissipation	PD	4.5	W
Forward Current	IF	400	mA
Pulse Forward Current*	IFP	600	mA
Reverse Voltage	VR	50	V
Operating Temperature	TOPR	-30 ~ +80	°C
Storage Temperature	TSTG	-30 ~+110	°C
Soldering Temperature**	TSOL	240	°C

* Duty=1% and Pulse Width=1us

** Soldering condition must be completed within 3 second at 260 °C.

Electro-Optical Characteristics						
Item	Symbol	Condition	Minimum	Typical	Maximum	Unit
Forward Voltage	VF	IF=240mA		10.0		V
Brightness	IV	IF=240mA		7000		mcd
Total Radiated Power	PO	IF=240mA		60		mW
Radiant Intensity	IE	IF=240mA		15		mW/sr
Reverse Current	VR	IR=10uA	50			V
Peak Wavelength	λP	IF=240mA	580	590	600	nm
Half Width	Δλ	IF=240mA		15		nm
Viewing Half Angle	θ1/2	IF=240mA		±60		deg

Heat sink is required thermal resistance <8K/W

