

FL780-03-80
Super Flux Mold Type LED

FL780-03-80 is an AlGaAs LED mounted on a lead frame and molded with super beam lens. On forward bias it emits a band of visible light which peaks 780nm. These devices are intended to be operated at pulsed current of 3A under maximum 4.5V.

Outer Dimension (Unit:mm)

<Specifications>

1. Product Name: Super Flux Mold Type LED
2. Type Number: FL780-03-80
3. Chip:
 - Chip material: GaAlAs
 - Chip Dimension: 800um x 800um
 - Peak Wavelength: 780nm
4. Package
 - Type: Super Beam Type LED
 - Resin Material: Epoxy Resin
 - Lead Frame: Silver Plated Copper

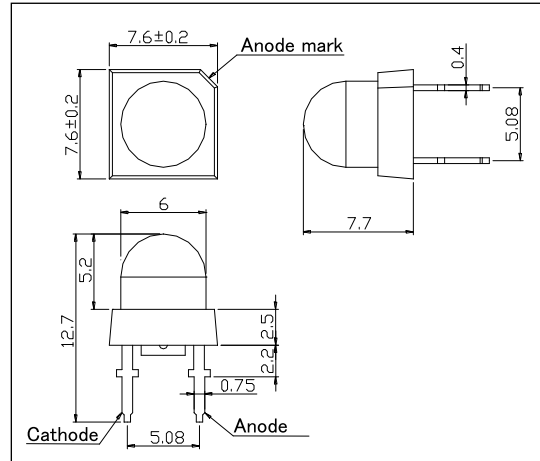

Absolute Maximum Ratings				
Item	Symbol	Maximum Rated Value	Unit	Ambient Temperature
Power Dissipation	PD	420	mW	Ta=25°C
Forward Current	IF	200	mA	Ta=25°C
Pulse Forward Current*	IFP	3000	mA	Ta=25°C
Reverse Voltage	VR	10	V	Ta=25°C
Thermal Resistance	Rthja	140	K/W	
Operating Temperature	TOPR	-30 ~ +85	°C	
Storage Temperature	TSTG	-40 ~ +100	°C	
Soldering Temperature**	TSOL	265	°C	

* Duty=1% and Pulse Width=10us

** Soldering Condition must be completed within 3 seconds at 265°C

Electro-Optical Characteristics [Ta=25°C typ.]						
Item	Symbol	Condition	Minimum	Typical	Maximum	Unit
Forward Voltage	VF	IF=200mA		1.8	2.1	V
Pulsed Forward Voltage	VF	IFP=3A		3.5	4.5	V
Reverse Current	IR	VR=10V			10	uA
Radiated Power*	PO	IF=200mA	50	80		mW
Radiant Intensity**	IE	IF=200mA		240		mW/sr
Peak Wavelength	λP	IF=200mA	765	780	795	nm
Half Width	Δλ	IF=200mA		25		nm
Viewing Half Angle	θ1/2	IF=200mA		± 10		deg
Rise Time	tr	IF=200mA		100		ns
Fall Time	tf	IF=200mA		100		ns

* Measured by S3584-08

** Measured by Tektronix J-6512

