

L760/840-05A

Bi-Color LED for Medical Analysis

L760/840-05A consists of DDH AlGaAs LEDs mounted on a lead frame with a clear epoxy lens. On forward bias, it emits a band of visible light which peaks 760nm and 840nm at anode common.

<Features>

- High Reliability
- High Power
- Anode Common
- Second Emission Free

<Specifications>

1. Product Name: Bi-Color LED
2. Type Number: L760/840-05A
3. Chip:
 - Chip material: AlGaAs(DDH structure)
 - Peak Wavelength: 760nm/840nm
4. Package
 - Type: Φ 5mm clear molding
 - Resin Material: Epoxy Resin
 - Lead Frame: Soldered(Lead Free)

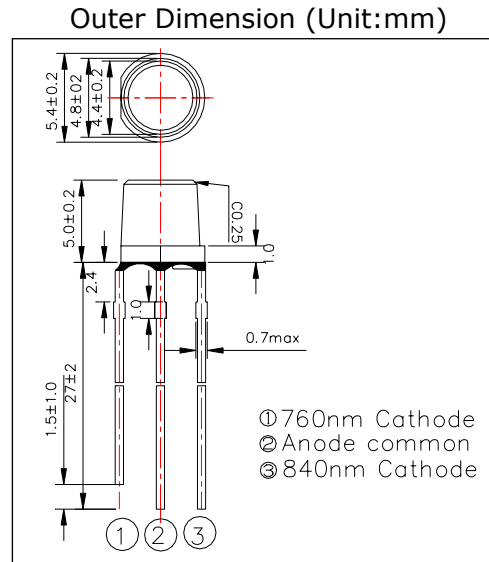

Absolute Maximum Ratings					
Item	Symbol	Maximum Rated Value		Unit	Ambient Temp.
		760nm	840nm		
Power Dissipation	PD	200	160	mW	Ta=25°C
Forward Current	IF	100		mA	Ta=25°C
Reverse Voltage	VR	10		V	Ta=25°C
Operating Temperature	TOPR	-30 ~ +85		°C	
Storage Temperature	TSTG	-30 ~ +100		°C	
Soldering Temperature*	TSOL	260		°C	

* Soldering condition must be completed within 3 second at 260 °C.

Electro-Optical Characteristics [Ta=25°C]									
Item	Symbol	Condition	Minimum		Typical		Maximum		Unit
			760	840	760	840	760	840	
Forward Voltage	VF	IF=50mA			1.85	1.55	2.0	1.7	V
Reverse Current	IR	VR=5V					10		uA
Total Radiated Power*	PO	IF=50mA	6	10	15	18			mW
Peak wavelength	λ P	IF=50mA	740	820	760	840	780	860	nm
Half Width	$\Delta\lambda$	IF=50mA			30	35			nm
Viewing Half Angle	θ 1/2	IF=50mA			±40				deg

* Measured by Photodyne #500

