

**L660N-05**

High Power Red LED For Damp Proof

L660N-05 is an AlGaInP LED mounted on a lead frame with a clear epoxy lens. This is designed for the highest Po and damp proof. On forward bias, it emits a band of visible light that peaks 660nm.

<Specifications>

1. Product Name: Red LED Lamp
2. Type Number: L660N-05
3. Chip:
  - Chip material: AlGaInP
  - Peak Wavelength: 660nm type
4. Package
  - Type: Φ5mm Clear Molding
  - Resin Material: Epoxy Resin
  - Lead Frame: Soldered(Lead Free)

Outer Dimension (Unit:mm)

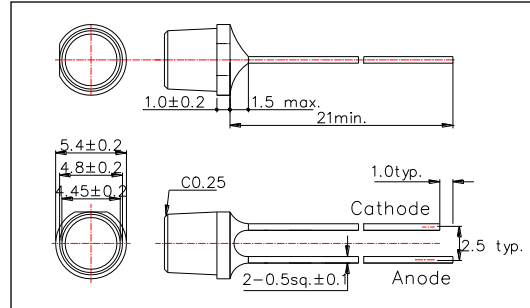

Absolute Maximum Ratings[Ta=25°C]			
Item	Symbol	Maximum Rated Value	Unit
Power Dissipation	PD	120	mW
Forward Current	IF	50	mA
Pulse Forward Current*	IFP	200	mA
Reverse Voltage	VR	5	V
Junction Temperature	Tj	100	°C
Thermal Resistance**	Rthjp	240	K/W
Operating Temperature	TOPR	-40 ~ +80	°C
Storage Temperature	TSTG	-40 ~ +100	°C
Soldering Temperature***	TSOL	265	°C

\* Duty=1% and Pulse Width=10us.

\*\* Junction - ambient, leads 7mm, soldered on PCB.

\*\*\* Soldering condition must be completed within 3 second at 265°C.

Electro-Optical Characteristics [Ta=25°C]						
Item	Symbol	Condition	Minimum	Typical	Maximum	Unit
Forward Voltage	VF	IF=20mA		2.1	2.3	V
Reverse Current	IR	VR=5V			-	uA
Total Radiated Power*	PO	IF=20mA	6	12		mW
Radiant Intensity	IE	IF=20mA		4		mW/sr
Brightness**	IV	IF=20mA		200		mcd
Peak Wavelength	λP	IF=20mA	650	660	670	nm
Half Width	Δλ	IF=20mA		18		nm
Viewing Half Angle	θ1/2	IF=20mA		±40		deg

\* Measured by Photodyne #500

\*\* Measured by Tektronix J-16



**Forward Current - Forward Voltage**

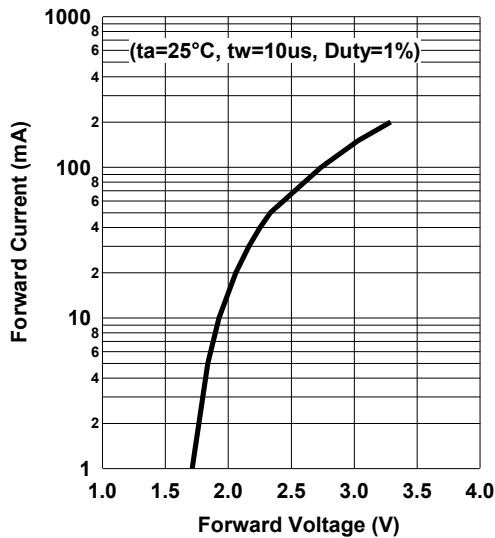

**Relative Radiant Intensity - Forward Current**

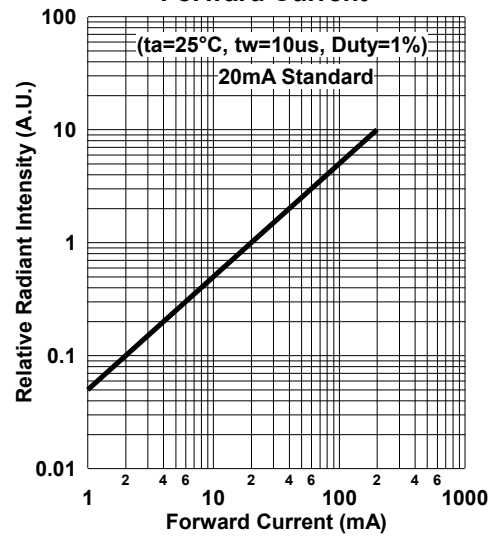

**Allowable Power Dissipation - Ambient Temperature**

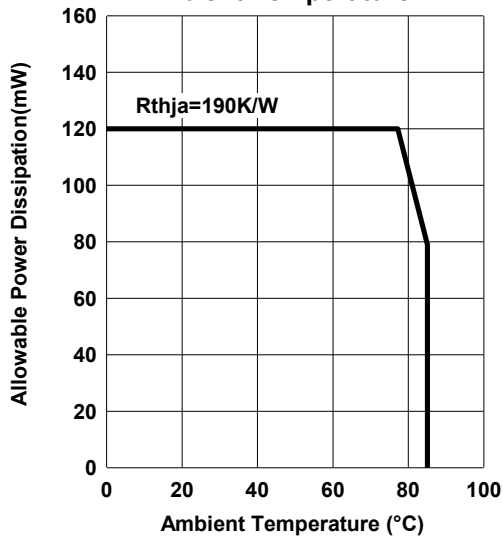

**Allowable Forward Current - Ambient Temperature**

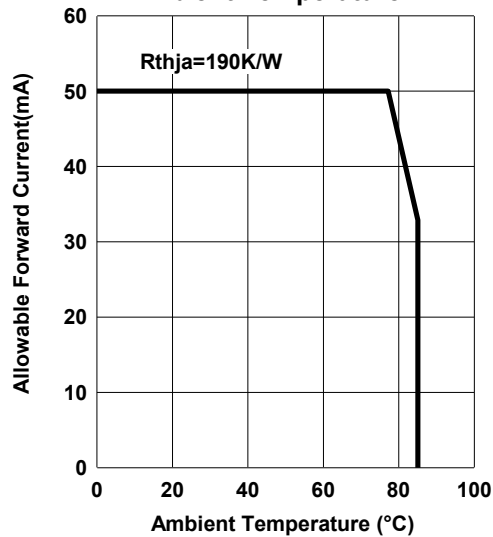

**Forward Voltage - Ambient Temperature**

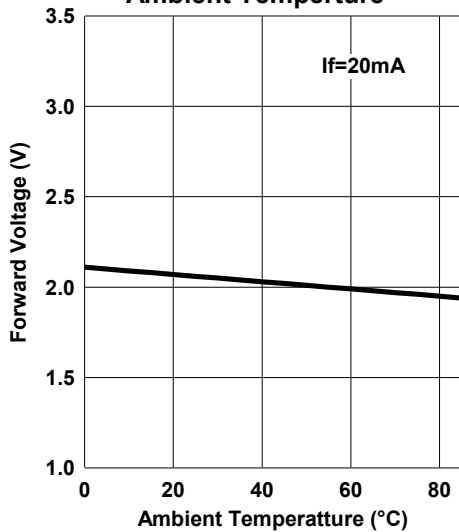

**Relative Radiant Intensity - Ambient Temperature**

