

## L810-40M32

### Stem Type LED with Ball Lens

L810-40M32 is an AlGaAs LED mounted on a TO-18 stem with a ball glass lens. It is designed for high beam use. On forward bias, it emits a spectral band of radiation which peaks at 810nm.

**<Features>**

- High Radiated Intensity
- High Reliability

**<Specifications>**

1. Product Name: Infrared LED Lamp
2. Type Number: L810-40M32
3. Chip:
  - Chip material: AlGaAs
  - Peak Wavelength: 810nm
4. Package
  - Type: TO-18 Stem
  - Lens: Ball Glass Lens
  - Cap: Gold Plated

Outer Dimension (Unit:mm)

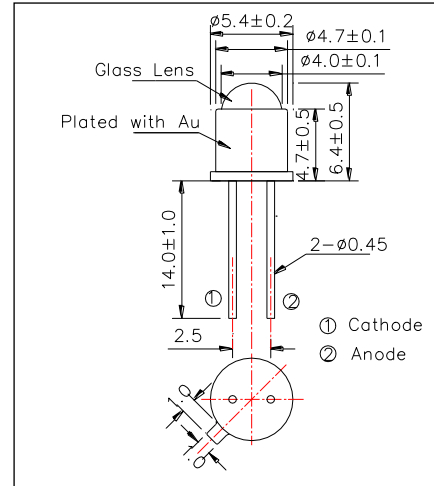

Absolute Maximum Ratings [Ta=25°C]			
Item	Symbol	Maximum Rated Value	Unit
Power Dissipation	PD	170	mW
Forward Current	IF	100	mA
Pulse Forward Current*	IFP	500	mA
Reverse Voltage	VR	5	V
Thermal Resistance	Rthja	230	K/W
Junction Temperature	Tj	100	°C
Operating Temperature	TOPR	-40 ~ +80	°C
Storage Temperature	TSTG	-40 ~ +100	°C
Soldering Temperature**	TSOL	265	°C

\* Duty=1% and Pulse Width=10μs.

\*\* Soldering condition must be completed within 3 second at 265 °C.

Electro-Optical Characteristics [Ta=25°C]						
Item	Symbol	Condition	Minimum	Typical	Maximum	Unit
Forward Voltage	VF	IF=50mA		1.60	1.80	V
Reverse Current	IR	VR=5V			10	uA
Total Radiated Power*	PO	IF=50mA	15	20		mW
Radiant Intensity**	IE	IF=50mA		80		mW/sr
Peak Wavelength	λP	IF=50mA	795	810	825	nm
Half Width	Δλ	IF=50mA		35		nm
Viewing Half Angle	θ1/2	IF=50mA		± 10		deg
Rise Time	tr	IF=50mA		60		ns
Fall Time	tf	IF=50mA		40		ns

\* Measured by Photodyne #500

\*\* Measured by Tektronix J-6512

