

L385-30M32

Stem Type LED with Ball Lens

L3875-30M32 is an InGaN LED mounted on TO-18 stem with ball glass lens, and designed for sensing devices.

On forward bias it emits a spectral band of radiation, which peaks at 385nm.

<Features>

- High Power
- High Reliability

<Specifications>

1. Product Name: LED Lamp
2. Type Number: L385-30M32
3. Chip:
 - Chip material: InGaN
 - Peak Wavelength: 385nm
4. Package
 - Stem: TO-18 Stem
 - Lens: Ball Glass Lens

Outer Dimension (Unit:mm)

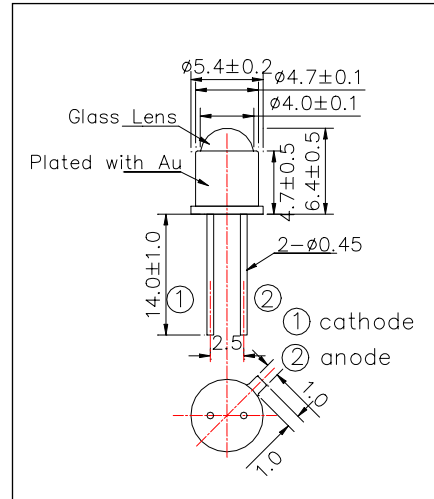

Absolute Maximum Ratings				
Item	Symbol	Maximum Rated Value	Unit	Ambient Temperature
Power Dissipation	PD	110	mW	Ta=25°C
Forward Current	IF	30	mA	Ta=25°C
Pulse Forward Current*	IFP	50	mA	Ta=25°C
Reverse Voltage	VR	3	V	Ta=25°C
Operating Temperature	TOPR	-30 ~ +85	°C	
Storage Temperature	TSTG	-30 ~ +100	°C	
Soldering Temperature**	TSOL	250	°C	

* Duty=1% and Pulse Width=10µs

** Soldering condition must be completed within 3 seconds at 250°C

Electro-Optical Characteristics						
Item	Symbol	Condition	Minimum	Typical	Maximum	Unit
Forward Voltage	VF	IF=20mA		3.6	4.3	V
Reverse Current	IR	VR=3V			10	uA
Total Radiated Power*	PO	IF=20mA	0.7	1.5		mW
Brightness	IV	IF=20mA		-		mcD
Radiant Intensity**	IE	IF=20mA	10	20		mW/sr
Peak Wavelength	λP	IF=20mA	375	385	395	nm
Half Width	Δλ	IF=20mA		17		nm
Viewing Half Angle	θ1/2	IF=20mA		±15		deg

* Measured by Ando Optical Multi Meter AQ2740&AQ2741

** Measured by Tektronix J-6512

