

**SMT870-27**

High Performance Infrared TOP IR LED with Lens

SMT870-27 consists of an AlGaAs LED mounted on the lead frame as TOP LED package with plastic ball lens. It is 44mW typical of output power and 40mW/sr of radiant intensity. It emits a spectral band of radiation at 870nm.

<Specifications>

1. Product Name: TOP IR LED
2. Type Number: SMT870-27
3. Chip:
  - Chip Material: AlGaAs
  - Dimension: 400um x 400nm
  - Peak Wavelength: 870nm
4. Package
  - Lead Frame Die: Silver Plated
  - Package Resin: PPA Resin
  - Lens: Epoxy Resin
  - Diameter:  $\Phi 2.6\text{mm}$

Outer Dimension (Unit:mm)

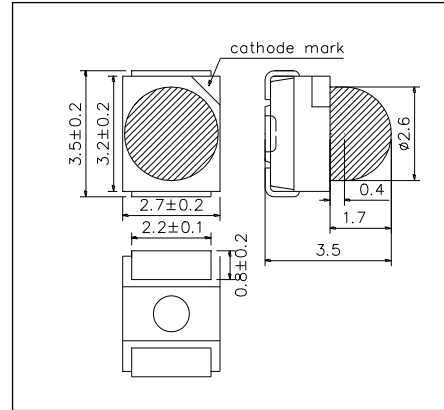

Absolute Maximum Ratings[Ta=25°C]			
Item	Symbol	Maximum Rated Value	Unit
Power Dissipation	PD	160	mW
Forward Current	IF	100	mA
Pulse Forward Current*	IFP	500	mA
Reverse Voltage	VR	5	V
Operating Temperature	TOPR	-20 ~ +80	°C
Storage Temperature	TSTG	-30 ~ +80	°C
Soldering Temperature**	TSOL	255	°C

\* Duty=1% and Pulse Width=10us.

\*\*Soldering condition must be completed within 10 second at 255°C.

Electro-Optical Characteristics [Ta=25°C]						
Item	Symbol	Condition	Minimum	Typical	Maximum	Unit
Forward Voltage	VF	IF=50mA DC		1.45	1.60	V
		IF=100mA, tp=20ms		1.50	1.80	
Reverse Current	IR	VR=5V			10	uA
Total Radiated Power*	PO	IF=50mA DC	16	22		mW
		IF=100mA, tp=20ms		44		
Radiant Intensity**	IE	IF=50mA DC		20		mW/sr
		IF=100mA, tp=20ms		40		
Peak Wavelength	$\lambda P$	IF=50mA DC	855	870	885	nm
Half Width	$\Delta\lambda$	IF=50mA DC		40		nm
Viewing Half Angle	$\theta_{1/2}$	IF=50mA DC		$\pm 28$		deg
Rise Time	tr	IF=50mA DC		15		ns
Fall Time	tf	IF=50mA DC		10		ns

\* Measured by Photodyne #500

\*\* Measured by Tektronix J-6512



◆ SMD Application  
IR-Reflow Soldering Profile for lead free soldering

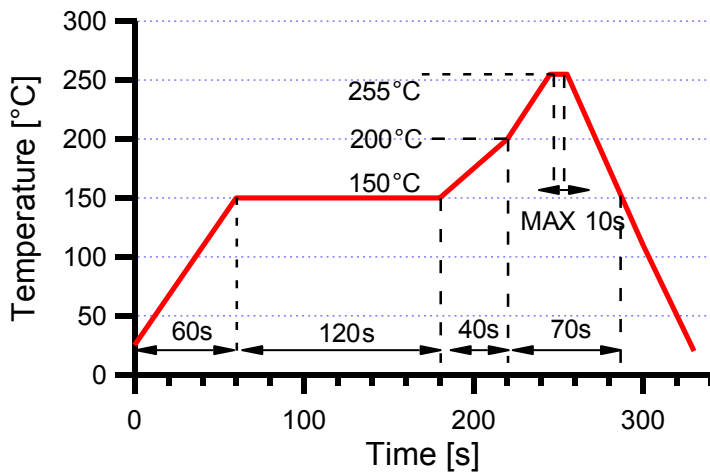

Recommended Land Layout (Unit: mm)

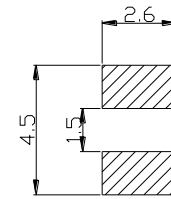

Don't put stress on SMD and a circuit board after soldering.

◆ SMD Packing  
Tape and Reel Dimensions (Unit: mm)

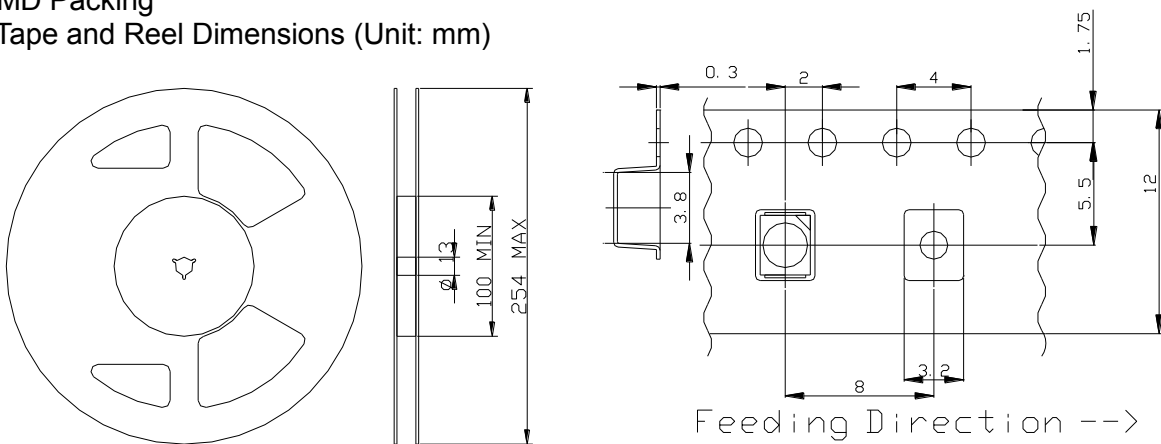

◆ Wrapping

Moisture barrier bag aluminum laminated film with a desiccant to keep out the moisture absorption during the transportation and storage.