

L890-66-60

Epoxy Lens Type Infrared Illuminator

L890-66-60 is a wide viewing and extremely high output power illuminator assembled with a total of 60 high efficiency AlGaAs diode chips, mounted on a metal stem TO-66 with AlN ceramics and covered with double coated clear silicone and epoxy resin. These devices are designed for high current operation with proper heat sinking to improve thermal conductive efficiency.

<Features>

- High Reliability
- Compact(TO-66) Package
- High Output Power at 890nm

<Application>

- For IR Search Light
- For CCD Lighting

<Specifications>

1. Product Name: IR Illuminator
2. Type Number: L890-66-60
3. Chip:
 - Chip material: AlGaAs
 - Peak Wavelength: 890nm typ.
4. Package
 - Type: TO-66 Stem with AlN
 - Lens: Clear Silicone and Epoxy Lens

Outer Dimension (Unit:mm)

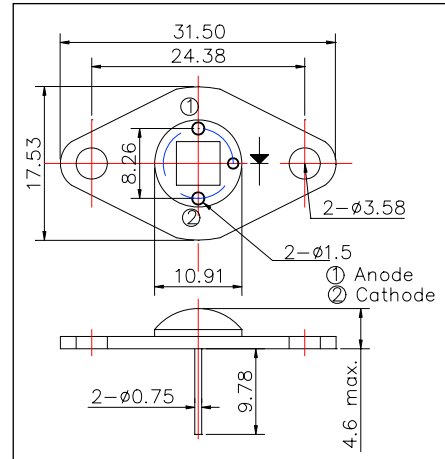

Absolute Maximum Ratings[Ta=25°C]			
Item	Symbol	Maximum Rated Value	Unit
Power Dissipation	PD	7.5	W
Forward Current	IF	1000	mA
Pulse Forward Current*	IFP	2.5	A
Reverse Voltage	VR	50	V
Operating Temperature	TOPR	-30 ~ +80	°C
Storage Temperature	TSTG	-30 ~ +100	°C
Soldering Temperature**	TSOL	240	°C

* Duty=1% and Pulse Width=1us

** Soldering condition must be completed within 3 second at 260°C.

Electro-Optical Characteristics						
Item	Symbol	Condition	Minimum	Typical	Maximum	Unit
Forward Voltage	VF	IF=800mA		7.0		V
Reverse Voltage	VR	IR=10uA	50			V
Total Radiated Power	PO	IF=800mA		850		mW
		IFP=5A		5500		
Radiant Intensity	IE	IF=800mA		300		mW/sr
Peak Wavelength	λP	IF=800mA	875	890	905	nm
Half Width	Δλ	IF=800mA		40		nm
Viewing Half Angle	θ1/2	IF=800mA		± 60		deg

Heat sink is required thermal resistance <8K/W

