

L870-66-60-550

IRED Illuminator with Glass Ball Lens Cap / Heat Sink

L870-66-60-550 is an extremely high beam and output power illuminator assembled with a total of 60 high efficiency AlGaAs diode chips, mounted on a metal stem TO-66 with AlN ceramics and sealed with glass ball lens cap and with heat sink for high current use.

<Features>

- High Reliability
- Compact(TO-66) Package
- High Output Power

<Specifications>

1. Product Name: IR Illuminator
2. Type Number: L870-66-60-550
3. Chip:
 - Chip material: AlGaAs
 - Peak Wavelength: 870nm typ.
4. Package
 - Type: TO-66 Stem with AlN
 - Lens: Glass Ball Lens
 - Heat sink: Aluminum

<Application>

- For IR Search Light
- For CCD Lighting
- For Night Vision Light Source

Outer Dimension (Unit:mm)

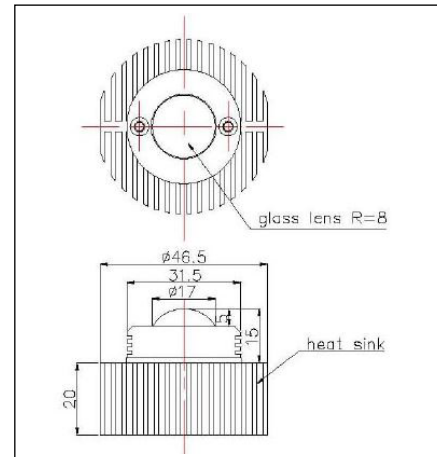

Absolute Maximum Ratings[Ta=25°C]			
Item	Symbol	Maximum Rated Value	Unit
Power Dissipation	PD	7.5	W
Forward Current	IF	1200	mA
Pulse Forward Current*	IFP	6	A
Reverse Voltage	VR	50	V
Operating Temperature	TOPR	-30 ~ +80	°C
Storage Temperature	TSTG	-30 ~ +110	°C
Soldering Temperature**	TSOL	240	°C

* Duty=1% and Pulse Width=1us

** Soldering condition must be completed within 3 second at 260°C.

Electro-Optical Characteristics						
Item	Symbol	Condition	Minimum	Typical	Maximum	Unit
Total Radiated Power	PO	IF=800mA		950		mW
		IFP=5A		5500		
Radiant Intensity	IE	IF=800mA		600		mW/sr
Forward Voltage	VF	IF=800mA		7.50		V
Reverse Current	VR	IR=10uA	50			V
Peak Wavelength	λP	IF=800mA	860	870	880	nm
Half Width	Δλ	IF=800mA		40		nm
Viewing Half Angle	θ1/2	IF=800mA		± 15		deg
Rise Time	Tr	IF=100mA		15		ns
Fall Time	tf	IF=100mA		10		ns

Heat sink is required thermal resistance <8K/W

