

L850D-35M13N

Stem Type LED with High Output Power

L850D-35M13N is an AlGaAs LED mounted on TO-46 stem and hermetically sealed with spherical glass ball lens being designed for ultra-narrow beam uses. On forward bias it emits a spectral band of radiation, which peaks at 850nm.

Outer Dimension (Unit:mm)

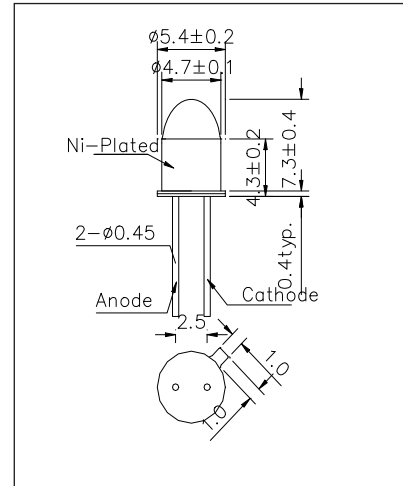

<Specifications>

1. Product Name: LED Lamp
2. Type Number: L850D-35M13N
3. Chip:
 - Chip material: AlGaAs
 - Chip Dimension: 350umx350um
 - Peak Wavelength: 850nm
4. Package
 - Type: TO-46 Stem
 - Lens: Spherical Glass
 - Cap: Nickel Plated

Absolute Maximum Ratings[Ta=25°C]			
Item	Symbol	Maximum Rated Value	Unit
Power Dissipation	PD	190	mW
Forward Current	IF	100	mA
Pulse Forward Current*	IFP	500	mA
Reverse Voltage	VR	5	V
Thermal Resistance	Rthja	330	K/W
Junction Temperature	Tj	100	°C
Operating Temperature	TOPR	-40 ~ +80	°C
Storage Temperature	TSTG	-40 ~+100	°C
Soldering Temperature**	TSOL	265	°C

* Duty=1% and Pulse Width=10μs

** Soldering Condition must be completed within 3 seconds at 265°C

Electro-Optical Characteristics [Ta=25°C typ.]						
Item	Symbol	Condition	Minimum	Typical	Maximum	Unit
Forward Voltage	VF	IF=50mA		1.6	1.9	V
Radiated Power*	PO	IF=50mA		8.8		mW
Radiant Intensity**	IE	IF=50mA		200		mW/sr
Peak Wavelength	λP	IF=50mA		850		nm
Half Width	Δλ	IF=50mA		30		nm
Viewing Half Angle	θ1/2	IF=50mA		±2		deg
Rise Time	tr	IF=50mA		90		ns
Fall Time	tr	IF=50mA		100		ns

* Measured by S3584-08

** Measured by CIE127-2007 Condition B



Forward Current - Forward Voltage

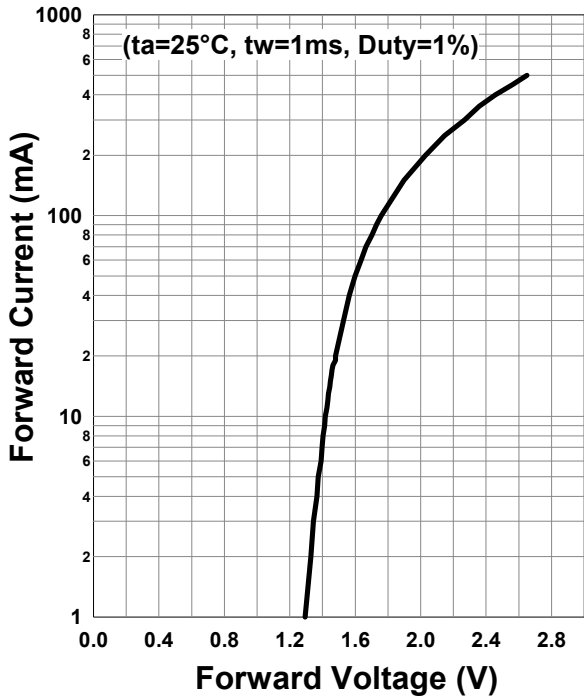

Relative Radiant Intensity - Forward Current

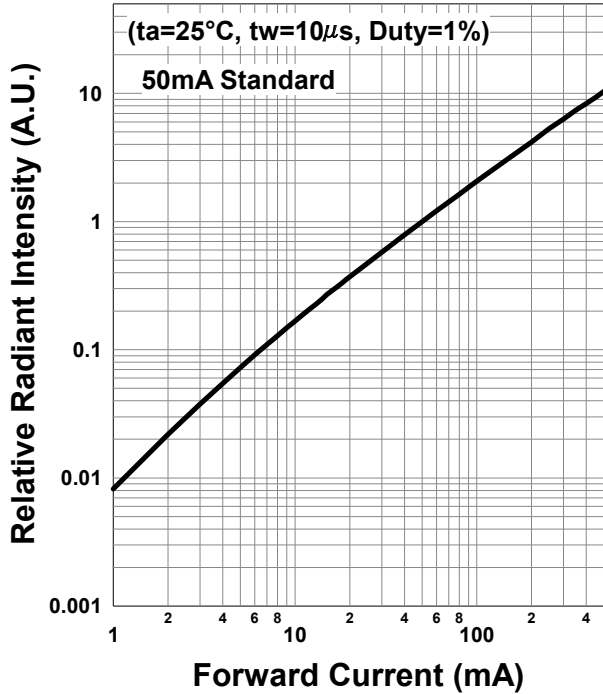

Forward Current - Pulse Duration

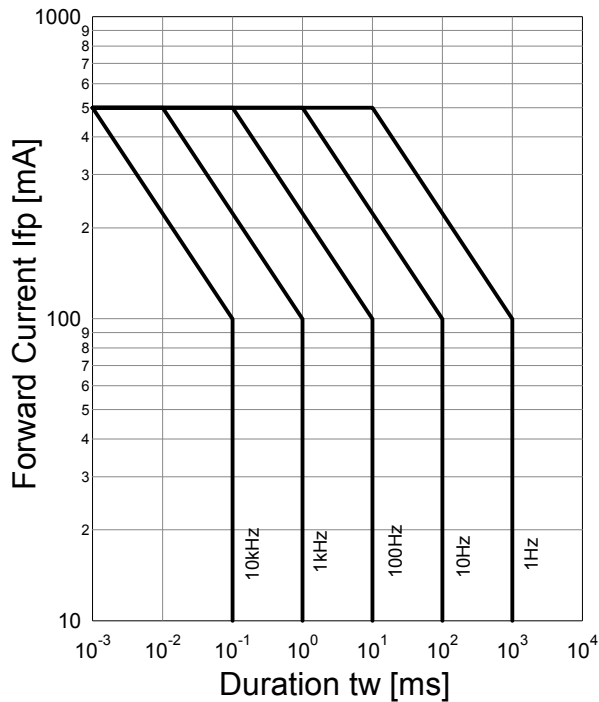

Allowable Forward Current - Ambient Temperature

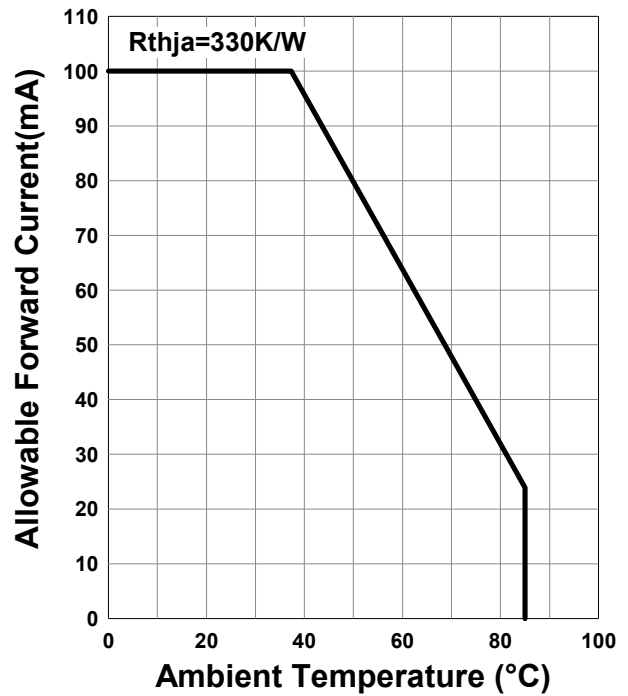

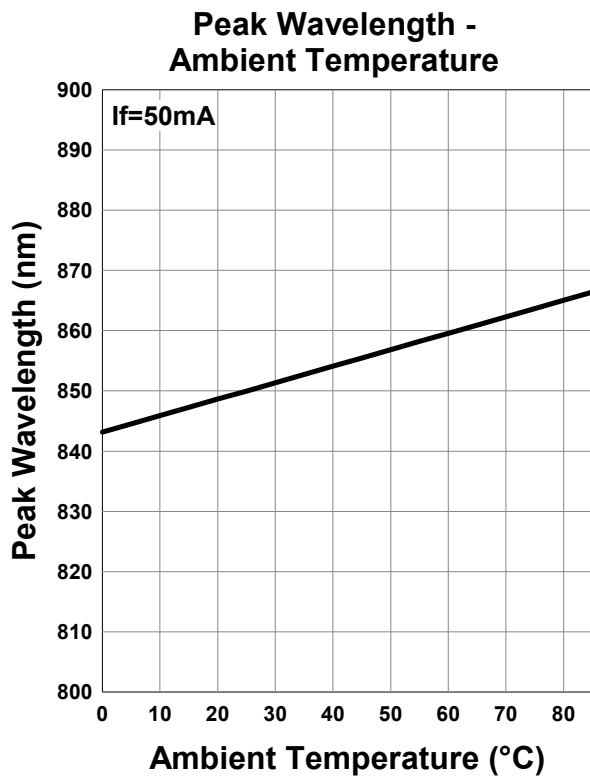
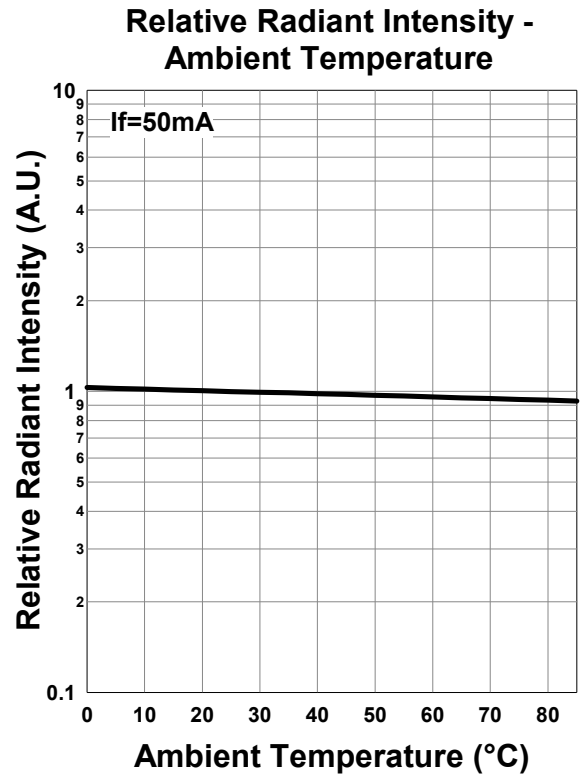
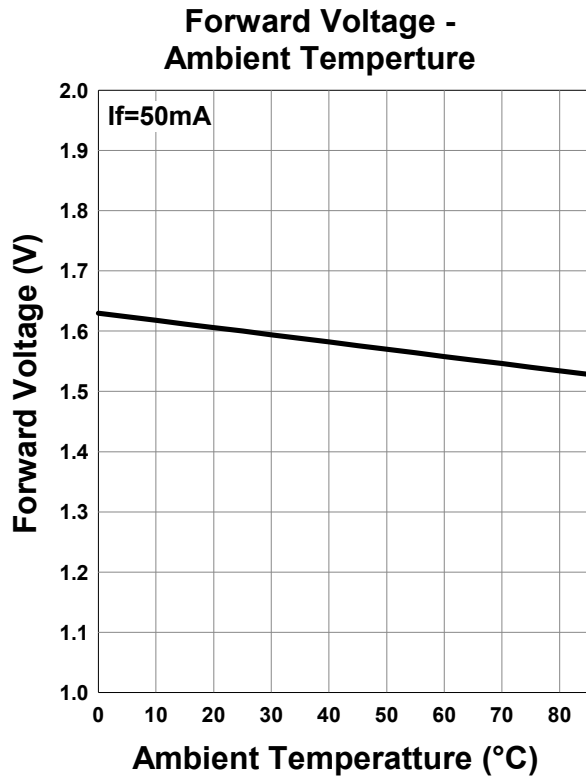

Relative Spectral Emission

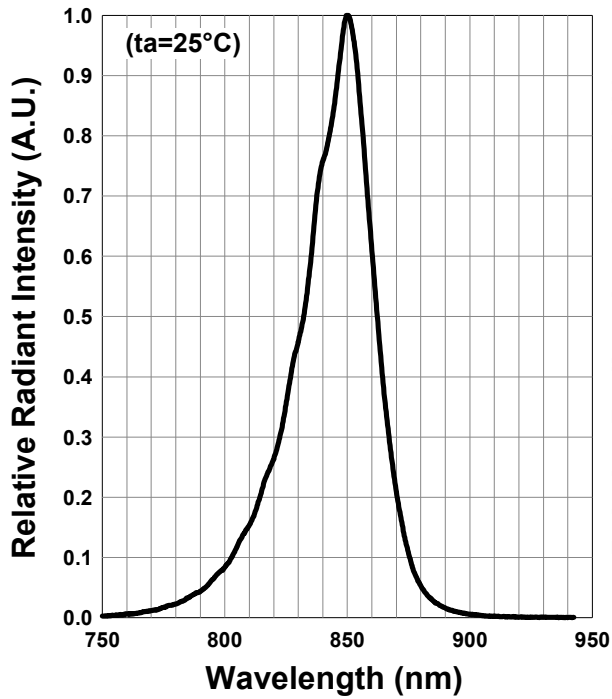

Radiation Characteristics

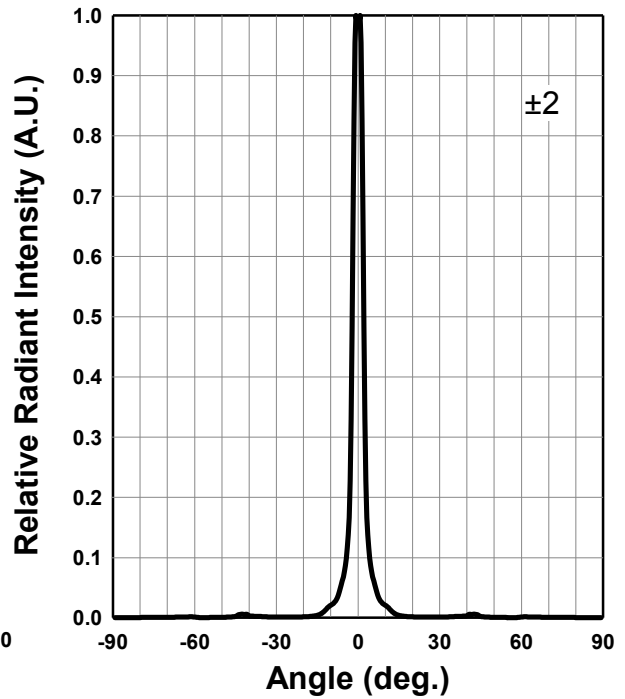

Relative Spectral Emission

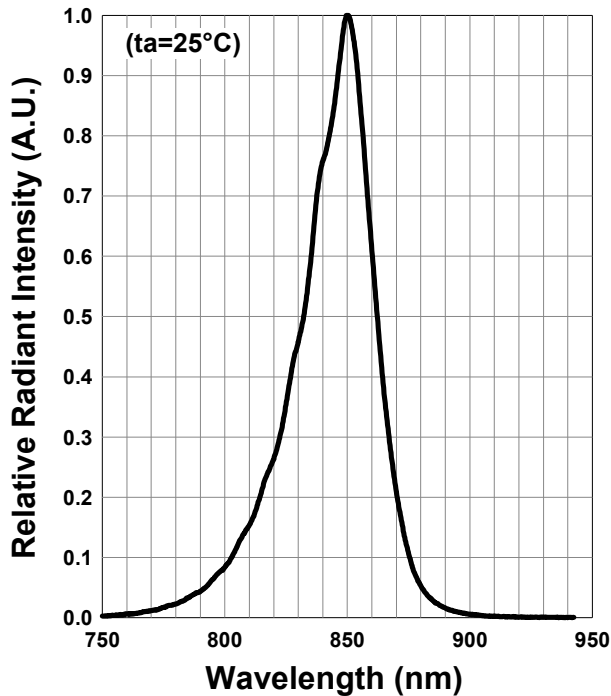

Radiation Characteristics

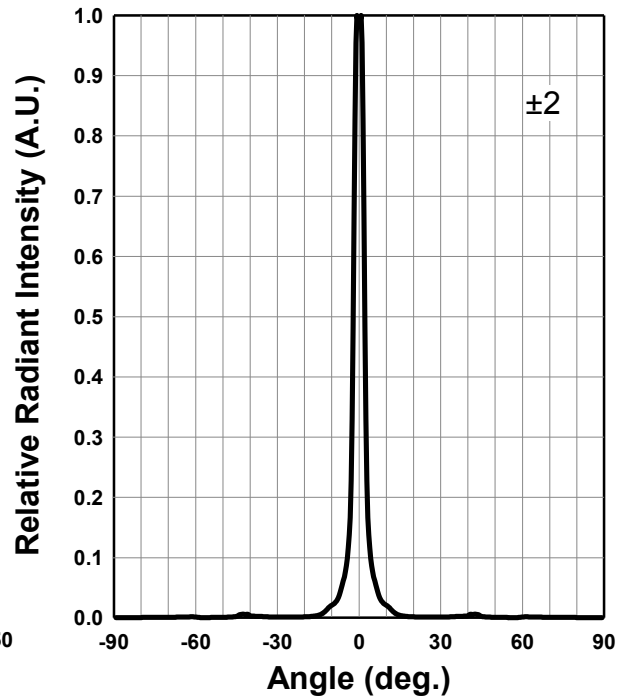

Disclaimer

Product specifications and data shown in this product catalog are subject to change without notice for the purposes of improving product performance, reliability, design, or otherwise.

Product data and parameters in this catalog are typical values based on reasonably up-to-date measurements. Product data and parameters may vary by user application and over time.

Products shown in this catalog are intended to be used for general electronic equipment. Products are not guaranteed for applications where product malfunction or failure may cause personal injury or death, including but not limited to life-supporting / saving devices, medical devices, safety devices, airplanes, aerospace equipment, automobiles, traffic control systems, and nuclear reactor control systems.