

L1550-35K42L

Stem Type LED with High Radiant Intensity

L1550-35K42L is an InGaAsP LED mounted on a TO-46 stem and designed for narrow viewing angle +/-8° type with hermetical unspherical glass lens can. On forward bias, it emits a band of radiation which peaks at 1550nm.

<Features>

- Narrow Viewing Angle
- High Radiated Intensity
- High Reliability

<Specifications>

1. Product Name: NIR LED Lamp
2. Type Number: L1550-35K42L
3. Chip:
 - Chip material: InGaAs/InP
 - Peak Wavelength: 1550nm typ.
4. Package
 - Type: TO-46 Stem
 - Lens: Unspherical Glass Lens
 - Cap: Gold Plated

Outer Dimension (Unit:mm)

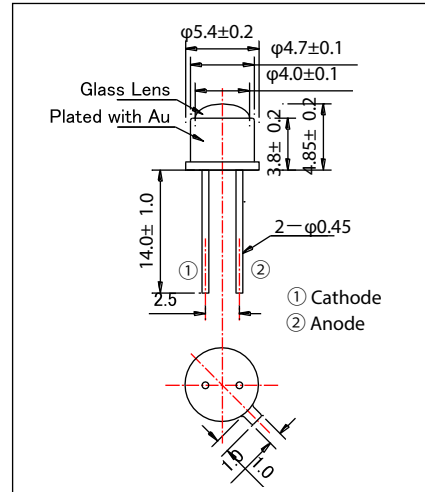

Absolute Maximum Ratings[Ta=25°C]			
Item	Symbol	Maximum Rated Value	Unit
Power Dissipation	PD	130	mW
Forward Current	IF	100	mA
Pulse Forward Current*	IFP	1000	A
Reverse Voltage	VR	3	V
Junction Temperature	Tj	100	°C
Thermal Resistance**	Rthjp	250	K/W
Operating Temperature	TOPR	-30 ~ +90	°C
Storage Temperature	TSTG	-40 ~ +100	°C
Soldering Temperature***	TSOL	265	°C

* Duty=1% and Pulse Width=10μs

** Junction - ambient, leads 7mm, soldered on PCB

*** Soldering condition must be completed within 3 second at 265 °C.

Electro-Optical Characteristics [Ta=25°C]						
Item	Symbol	Condition	Minimum	Typical	Maximum	Unit
Forward Voltage	VF	IF=50mA		0.95	1.35	V
Reverse Current	IR	VR=5V			10	uA
Total Radiated Power*	PO	IF=50mA	0.6	1.1		mW
Radiant Intensity**	IE	IF=50mA		3.5		mW/sr
Peak Wavelength	λP	IF=50mA	1500	1550	1600	nm
Half Width	Δλ	IF=50mA		115		nm
Centroid Wavelength	λC	IF=50mA		1525		nm
Viewing Half Angle	θ1/2	IF=50mA		±8		deg
Rise Time	tr	IF=50mA		10		ns
Fall Time	tf	IF=50mA		10		ns

* Measured by HPK G8370-85

** Measured by Ando Optical Multi Meter AQ2140&AQ2742

