

L1200-66-60

Epoxy Lens Type Infrared Illuminator

L1200-66-60 is a wide viewing and extremely high output power illuminator assembled with a total of 60 high efficiency InGaAsP diode chips, mounted on a metal stem TO-66 with AlN ceramics and covered with double coated clear silicone and epoxy resin. These devices are designed for high current operation with proper heat sinking to improve thermal conductive efficiency.

<Features>

- High Reliability
- Compact(TO-66) Package
- High Output Power at 1200nm

<Application>

- For IR Search Light
- For CCD Lighting

<Specifications>

1. Product Name: IR Illuminator
2. Type Number: L1200-66-60
3. Chip:
 - Chip material: InGaAsP
 - Peak Wavelength: 1200nm typ.
- 4.Package
 - Type: TO-66 Stem with AlN
 - Lens: Clear Silicone and Epoxy Lens

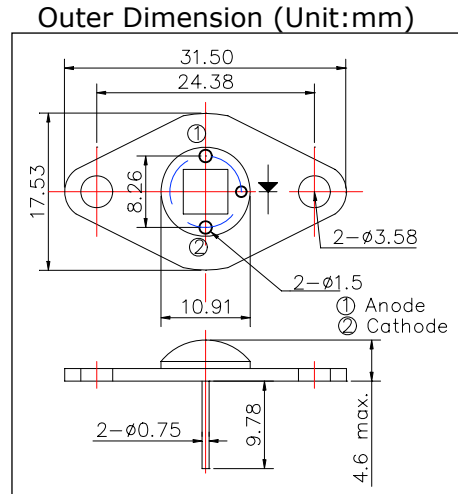

Absolute Maximum Ratings[Ta=25°C]			
Item	Symbol	Maximum Rated Value	Unit
Power Dissipation	PD	5.5	W
Forward Current	IF	800	mA
Pulse Forward Current*	IFP	5	V
Operating Temperature	TOPR	-30 ~ +80	°C
Storage Temperature	TSTG	-30 ~ +110	°C
Soldering Temperature**	TSOL	240	°C

* Duty=1% and Pulse Width=1us.

** Soldering condition must be completed within 3 second at 260°C.

Electro-Optical Characteristics						
Item	Symbol	Condition	Minimum	Typical	Maximum	Unit
Total Radiated Power*	PO	IF=600mA		60		mW
Forward Voltage	VF	IF=600mA		6.0		V
Reverse Current	VR	IR=10uA	30			V
Peak Wavelength	λP	IF=600mA	1150	1200	1250	nm
Half Width	Δλ	IF=600mA		60		nm
Viewing Half Angle	θ1/2	IF=600mA		± 60		deg
Rise Time	tr	IF=100mA		15		ns
Fall Time	tf	IF=100mA		10		ns

* Measured by Ando Optical Multi Meter AQ2140&AQ2742.

Heat sink is required to protect LED at 60°C or less.

