

**FL740-03-80**  
Super Flux Mold Type LED

FL740-03-80 is an AlGaAs LED mounted on a lead frame and molded with super flux lens. On forward bias it emits a band of visible light which peaks 740nm.

<Specifications>

1. Product Name: Super Flux Mold Type LED
2. Type Number: FL740-03-80
3. Chip:
  - Chip material: GaAlAs
  - Chip Dimension: 800um x 800um
  - Peak Wavelength: 740nm
4. Package
  - Type: Lead Frame Type LED
  - Resin Material: Epoxy Resin
  - Lead Frame: Silver Plated Copper

Outer Dimension (Unit:mm)

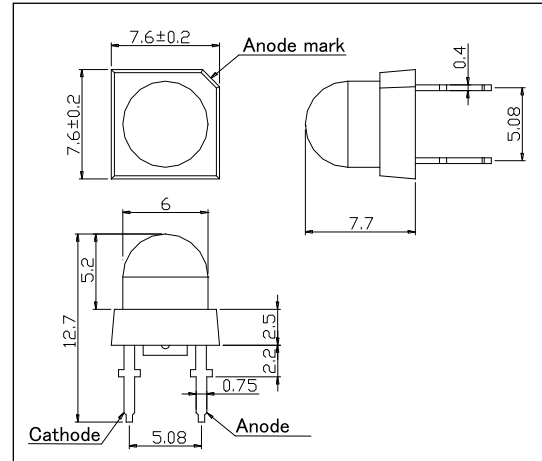

Absolute Maximum Ratings				
Item	Symbol	Maximum Rated Value	Unit	Ambient Temperature
Power Dissipation	PD	450	mW	Ta=25°C
Forward Current	IF	200	mA	Ta=25°C
Pulse Forward Current*	IFP	2000	mA	Ta=25°C
Reverse Voltage	VR	10	V	Ta=25°C
Operating Temperature	TOPR	-30 ~ +85	°C	
Storage Temperature	TSTG	-30 ~ +100	°C	
Soldering Temperature**	TSOL	265	°C	

\* Duty=1% and Pulse Width=10us

\*\* Soldering Condition must be completed within 3 seconds at 265°C

Electro-Optical Characteristics [Ta=25°C typ.]						
Item	Symbol	Condition	Minimum	Typical	Maximum	Unit
Forward Voltage	VF	IF=100mA		1.65	2.1	V
Pulsed Forward Voltage	VF	IFP=2A		3.2		V
Reverse Current	IR	VR=10V			10	uA
Radiated Power*	PO	IF=100mA	16	20		mW
Radiant Intensity**	IE	IF=100mA		70		mW/sr
Peak Wavelength	λP	IF=50mA	725	740	755	nm
Half Width	Δλ	IF=50mA		25		nm
Viewing Half Angle	θ1/2	IF=50mA		± 12		deg
Rise Time	tr	IF=50mA		80		ns
Fall Time	tf	IF=50mA		80		ns

\* Measured by Photodyne #500

\*\* Measured by Tektronix J-6512

