

L750/850-04A

Bi-Color LED for Medical Analysis

Bi-color LED L750/850-04A consists of DDH structure AlGaAs LEDs mounted on a lead frame with a clear epoxy lens.

On forward bias, it emits a band of visible light, which peaks 750nm and 850nm by anode common.

<Features>

- High Reliability
- High Power
- Anode Common

<Specifications>

1. Product Name: Bi-color LED
2. Type Number: L750/850-04A
3. Chip:
 - Chip material: AlGaAs(DDH structure)
 - Peak Wavelength: 750/850nm typ.
4. Package
 - Type: Φ 5mm clear molding
 - Resin Material: Epoxy Resin
 - Lead Frame: Soldered(Lead Free)

Outer Dimension (Unit:mm)

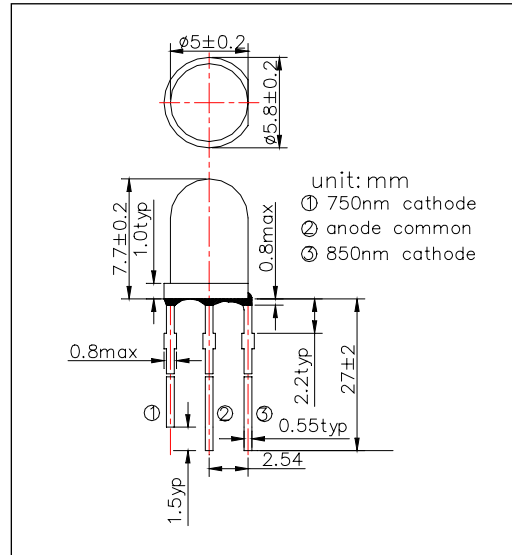

Absolute Maximum Ratings					
Item	Symbol	Maximum Rated Value		Unit	Ambient Temperature
		750nm	850nm		
Power Dissipation	PD	200	160	mW	Ta=25°C
Forward Current	IF	100		mA	Ta=25°C
Reverse Voltage	IR	10		V	Ta=25°C
Operating Temperature	TOPR	-30 ~ +85		°C	
Storage Temperature	TSTG	-30 ~ +100		°C	
Soldering Temperature*	TSOL	260		°C	

* Soldering condition must be completed within 3 second at 260°C.

Electro-Optical Characteristics [Ta=25°C typ.]									
Item	Symbol	Condition	Minimum		Typical		Maximum		Unit
			750	850	750	850	750	850	
Forward Voltage	VF	IF=50mA			1.85	1.55	2.00	1.70	V
Reverse Current	IR	VR=5V					10		uA
Total Radiated Power*	PO	IF=50mA	8.0	12.0	15.0	18.0			mW
Peak Wavelength	λ P	IF=50mA	730	830	750	850	770	870	nm
Half Width	$\Delta\lambda$	IF=50mA			30	35			nm
Viewing Half Angle	θ 1/2	IF=50mA			±20				Deg.

* Measured by Photodyne #500

