

L670-42V Infrared LED Lamp

L670-42V is an AlGaAs LED mounted on a lead frame with a clear epoxy lens. On forward bias, it emits a high power radiation of typical 8mW with peak wavelength at 675nm.

<Specifications>

1. Product Name: Infrared LED Lamp
2. Type Number: L670-42V
3. Chip:
 - Chip material: AlGaAs
 - Peak Wavelength: 675nm typ.
4. Package
 - Type: Φ4mm Clear Molding
 - Resin Material: Epoxy Resin
 - Lead Frame: Soldered(Lead Free)

Outer Dimension (Unit:mm)

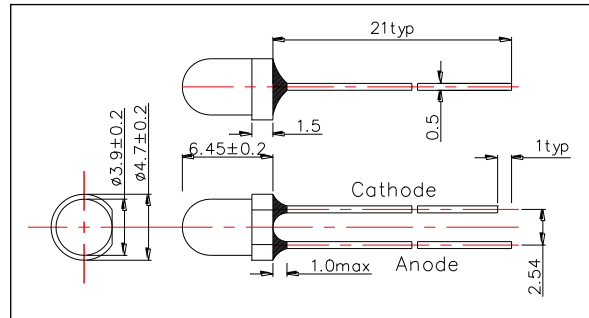

Absolute Maximum Ratings				
Item	Symbol	Maximum Rated Value	Unit	Ambient Temp.
Power Dissipation	PD	110	mW	Ta=25°C
Forward Current	IF	50	mA	Ta=25°C
Pulse Forward Current*	IFP	200	mA	Ta=25°C
Reverse Voltage	VR	5	V	Ta=25°C
Operating Temperature	TOPR	-30 ~ +85	°C	
Storage Temperature	TSTG	-30 ~ +100	°C	
Soldering Temperature**	TSOL	265	°C	

* Duty=1% and Pulse Width=10us.

** Soldering condition must be completed within 3 second at 265°C.

Electro-Optical Characteristics [Ta=25°C]						
Item	Symbol	Condition	Minimum	Typical	Maximum	Unit
Forward Voltage	VF	IF=20mA		1.8	2.3	V
Reverse Current	IR	VR=5V			10	uA
Total Radiated Power*	PO	IF=20mA	3	6		mW
Radiant Intensity**	IE	IF=20mA		13		mW/sr
Peak Wavelength	IV	IF=20mA	670	675	680	nm
Half Width	Δλ	IF=20mA		20		nm
Viewing Half Angle	θ1/2	IF=20mA		±22		deg
Rise Time	tr	IF=20mA		80		ns
Fall Time	tf	IF=20mA		80		ns

* Measured by Photodyne #500

** Measured by Tektronix J-6512

