

L430/565-04A

Bi-Color LED for Mesical Analysis

L430/565-04A consists of GaN(430nm) and GaP(565nm) LEDs mounted on a lead frame with a clear epoxy lens. On forward bias, it emits a band of visible light which peaks 430nm and 565nm at cathode common.

<Features>

- High Reliability
- High Power
- Cathode Common

<Specifications>

1. Product Name: Bi-Color LED
2. Type Number: L430/565-04A
3. Chip:
 - Chip material: GaN/GaP
 - Peak Wavelength: 430nm/565nm
4. Package
 - Type: Φ 5mm clear molding
 - Resin Material: Epoxy Resin
 - Lead Frame: Soldered(Lead Free)

Outer Dimension (Unit:mm)

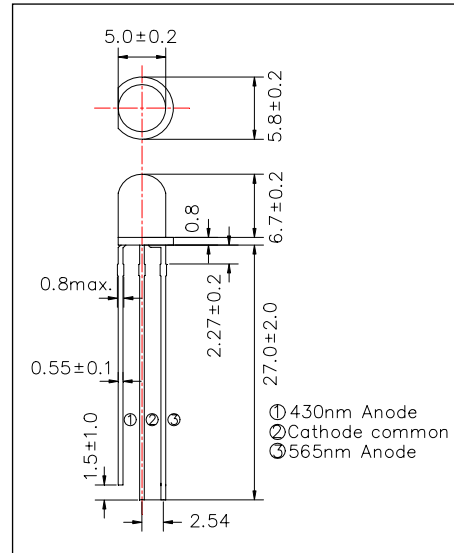

Absolute Maximum Ratings					
Item	Symbol	Maximum Rated Value		Unit	Ambient Temp.
		430nm	565nm		
Power Dissipation	PD	250	130	mW	Ta=25°C
Forward Current	IF	50	50	mA	Ta=25°C
Reverse Voltage	VR	10		V	Ta=25°C
Operating Temperature	TOPR	-30 ~ +85		°C	
Storage Temperature	TSTG	-30 ~ +100		°C	
Soldering Temperature*	TSOL	260		°C	

* Soldering condition must be completed within 3 second at 260 °C.

Electro-Optical Characteristics [Ta=25°C]									
Item	Symbol	Condition	Minimum		Typical		Maximum		Unit
			430	565	430	565	430	565	
Forward Voltage	VF	IF=20mA			4.0	2.2	5.0	2.4	V
Reverse Current	IR	VR=5V						10	uA
Reverse Current	IR	VR=10V					100		nA
Total Radiated Power*	PO	IF=20mA	0.2	0.1	0.4	0.2	0.5	0.3	mW
Peak wavelength	λ P	IF=20mA	418	562	425	565	432	568	nm
Half Width	Δ λ	IF=20mA			50	35			nm
Viewing Half Angle	θ 1/2	IF=20mA			±20				deg

* Measured by Photodyne #500

