

L660N/850-04A

Bi-Color LED for Medical Analysis

Bi-color LED of L660N/850-04A consists of AlGaInP and AlGaAs LEDs mounted on a lead frame with a clear epoxy lens.

On forward bias it emits a band of visible light which peaks 660nm and 850nm at anode common.

<Features>

- High Reliability
- High Power
- Anode Common

<Specifications>

1. Product Name: Bi-color LED
2. Type Number: L660N/850-04A
3. Chip:
 - Chip material: AlGaInP/AlGaAs
 - Peak Wavelength: 660nm and 850nm typ.
4. Package
 - Type: Φ 5mm clear molding
 - Resin Material: Epoxy Resin
 - Lead Frame: Soldered(Lead Free)

Outer Dimension (Unit:mm)

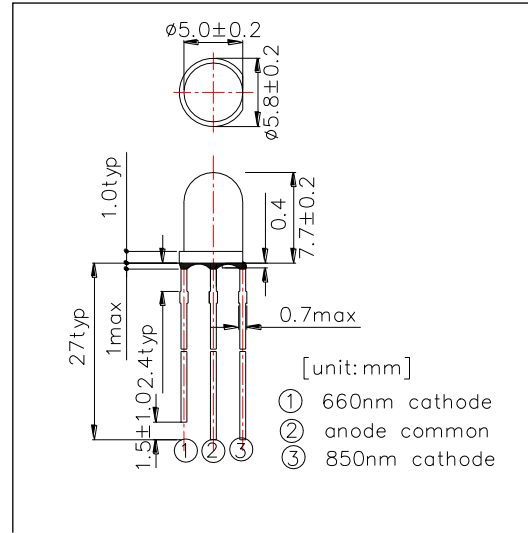

Absolute Maximum Ratings					
Item	Symbol	Maximum Rated Value		Unit	Ambient Temperature
		660nm	850nm		
Power Dissipation	PD	120	160	mW	Ta=25°C
Forward Current	IF	50	50	mA	Ta=25°C
Reverse Voltage	IR	5		V	Ta=25°C
Operating Temperature	TOPR	-40 ~ +85		°C	
Storage Temperature	TSTG	-40 ~ +100		°C	
Soldering Temperature	TSOL	265		°C	

Soldering condition: Soldering condition must be completed within 3 seconds at 265°C

Electro-Optical Characteristics [Ta=25°C]									
Item	Symbol	Condition	Minimum		Typical		Maximum		Unit
			660	850	660	850	660	850	
Forward Voltage	VF	IF=20mA			2.1	1.4	2.3	1.6	V
Reverse Current	IR	VR=5V							uA
Total Radiated Power	PO	IF=20mA	8.0	4.8	15.0	7.0			mW
Peak Wavelength	λ P	IF=20mA	650	830	660	850	670	870	nm
Half Width	$\Delta\lambda$	IF=20mA			18	35			nm
Viewing Half Angle	θ 1/2	IF=20mA			±20				Deg.

Total Radiated Power is measured by Photodyne #500.
Radiant Intensity is measured by Tektronix J-6512

