

L1300/1450/1550/PD-35B32
Multi-Wavelength LED

This product consists of InGaAs LEDs and an InGaAs PD mounted on TO-18 stem with a spherical glass lens. And it is designed to monitor reflected light through detector for controlling its own output power.

Outer Dimension (Unit:mm)

<Specifications>

1. Product Name: Multi-Wavelength LED Lamp
2. Type Number: L1300/1450/1550/PD-35B32
3. Chip:
 - Chip Material: InGaAs(LED/PD)
 - Peak Wavelength: 1300,1450,1550nm
4. Package:
 - Stem: TO-18, 5pins type
 - Lens: Φ5mm Spherical Glass

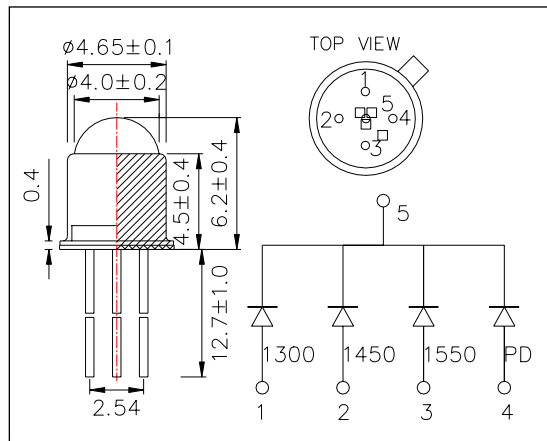

Absolute Maximum Ratings/per each one chip[Ta=25°C]				
Device	Item	Symbol	Maximum Rated Value	Unit
LED	Power Dissipation	PD	120	mW
LED	Forward Current	IF	100	mA
LED	Pulse Forward Current	IFP	1000	mA
LED	Reverse Voltage	VR	5	V
PD	Reverse Voltage	VR	10	V
	Operating Temperature	TOPR	-20 ~ +80	°C
	Storage Temperature	TSTG	-30 ~ +100	°C
	Soldering Temperature*	TSOL	240	°C

* Soldering condition must be completed within 3 seconds at 240°C and it is allowed in the area apart 3mm from the bottom of the lamp.

Electro-Optical Characteristics/per each one chip [Ta=25°C]													
Device	Item	Symbol	Condition	Minimum			Typical			Maximum			Unit
				1300	1450	1550	1300	1450	1550	1300	1450	1550	
LED	Forward Voltage	VF	IF=20mA				0.8	0.8	0.8	1.3	1.3	1.3	V
	Reverse Current	IR	VR=5V							10			uA
	T. Radiated Power*	PO	IF=20mA				1.3	1.0	0.8				mW
	Peak Wavelength	λP	IF=20mA	1250	1400	1500	1300	1450	1550	1350	1500	1600	nm
	Half Width	Δλ	IF=20mA				75	75	75				nm
PD	Output Current	IL	IF=20mA VR=0V				45	35	35				uA
	Dark Current	ID	VR=10V							100			nA

* Measured by Photodyne #500 (Radiated Power of NIR LED is measured by Ando Optical Multi Meter AQ2140&AQ2742)

