

SMT870-23 High Performance Infrared TOP LED with Lens

SMT870-23 consists of an AlGaAs LED mounted on the lead frame as TOP LED package with plastic ball lens and is 22mW typical of output power and 40mW/sr of radiant Intensity. It emits a spectral band of radiation at 870nm.

◆ Outer dimension (Unit:mm)

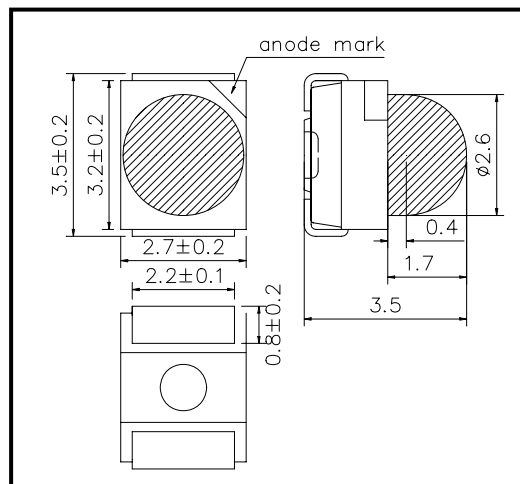

◆ Specifications

- | | |
|---------------------|---------------|
| 1) Product Name | TOP IR LED |
| 2) Type No. | SMT870-23 |
| 3) Chip | |
| (1) Chip Material | AlGaAs |
| (2) Peak Wavelength | 870nm typ. |
| 4) Package | |
| (1) Lead Frame Die | Silver Plated |
| (2) Package Resin | PPA Resin |
| (3) Lens | Epoxy Resin |
| (4) Diameter | Φ2.6mm |

◆ Absolute Maximum Rating

Item	Symbol	Maximum Rated Value	Unit	Ambient Temperature
Power Dissipation	P _D	160	mW	T _a =25°C
Forward Current	I _F	100	mA	T _a =25°C
Pulse Forward Current	I _{FP}	500	mA	T _a =25°C
Reverse Voltage	V _R	5	V	T _a =25°C
Operating Temperature	T _{OPR}	-20 ~ +80	°C	
Storage Temperature	T _{STG}	-30 ~ +80	°C	
Soldering Temperature	T _{SOL}	240	°C	

‡Pulse Forward Current condition: Duty=1% and Pulse Width=10us.

‡Soldering condition: Soldering condition must be completed within 3 seconds at 230°C

◆ Electro-Optical Characteristics [T_a=25°C]

Item	Symbol	Condition	Minimum	Typical	Maximum	Unit
Forward Voltage	V _F	I _F =50mA		1.50	1.70	V
Reverse Current	I _R	V _R =5V			10	uA
Total Radiated Power	P _O	I _F =50mA	16.0	22.0		mW
Radiant Intensity	I _E	I _F =50mA	20	40		mW/sr
Peak Wavelength	λ _P	I _F =50mA	855	870	885	nm
Half Width	Δλ	I _F =50mA		40		nm
Viewing Half Angle	θ _{1/2}	I _F =50mA		±15		deg.
Rise Time	t _r	I _F =50mA		15		ns
Fall Time	t _f	I _F =50mA		10		ns

‡Total Radiated Power is measured by Photodyne #500

‡Radiant Intensity is measured by Tektronix J-6512.