

## SMT850-23 High Performance Infrared TOP LED with Lens

SMT850-23 consists of an AlGaAs LED mounted on the lead frame as TOP LED package with plastic ball lens and is 22mW typical of output power and 40mW/sr of radiant Intensity. It emits a spectral band of radiation at 850nm.

### ◆ Outer dimension (Unit:mm)

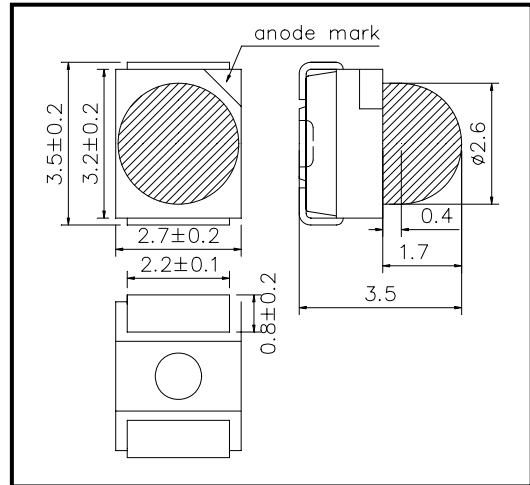

### ◆ Specifications

1) Product Name	TOP IR LED
2) Type No.	SMT850-23
3) Chip	
(1) Chip Material	AlGaAs
(2) Chip Dimension	400um*400nm
(3) Peak Wavelength	850nm typ.
4) Package	
(1) Lead Frame Die	Silver Plated
(2) Package Resin	PPA Resin
(3) Lens	Epoxy Resin
(4) Diameter	Φ2.6mm

### ◆ Absolute Maximum Rating

Item	Symbol	Maximum Rated Value	Unit	Ambient Temperature
Power Dissipation	P <sub>D</sub>	160	mW	T <sub>a</sub> =25°C
Forward Current	I <sub>F</sub>	100	mA	T <sub>a</sub> =25°C
Pulse Forward Current	I <sub>FP</sub>	500	mA	T <sub>a</sub> =25°C
Reverse Voltage	V <sub>R</sub>	5	V	T <sub>a</sub> =25°C
Operating Temperature	T <sub>OPR</sub>	-20 ~ +80	°C	
Storage Temperature	T <sub>STG</sub>	-30 ~ +80	°C	
Soldering Temperature	T <sub>SOL</sub>	240	°C	

‡Pulse Forward Current condition: Duty=1% and Pulse Width=10us.

‡Soldering condition: Soldering condition must be completed within 3 seconds at 230°C

### ◆ Electro-Optical Characteristics [T<sub>a</sub>=25°C]

Item	Symbol	Condition	Minimum	Typical	Maximum	Unit
Forward Voltage	V <sub>F</sub>	I <sub>F</sub> =50mA		1.50	1.70	V
Reverse Current	I <sub>R</sub>	V <sub>R</sub> =5V			10	uA
Total Radiated Power	P <sub>O</sub>	I <sub>F</sub> =50mA	16.0	22.0		mW
Radiant Intensity	I <sub>E</sub>	I <sub>F</sub> =50mA	20	40		mW/sr
Peak Wavelength	λ <sub>P</sub>	I <sub>F</sub> =50mA	835	850	865	nm
Half Width	Δλ	I <sub>F</sub> =50mA		40		nm
Viewing Half Angle	θ <sub>1/2</sub>	I <sub>F</sub> =50mA		±15		deg.
Rise Time	t <sub>r</sub>	I <sub>F</sub> =50mA		15		ns
Fall Time	t <sub>f</sub>	I <sub>F</sub> =50mA		10		ns

‡Total Radiated Power is measured by Photodyne #500

‡Radiant Intensity is measured by Tektronix J-6512.