

SMT830/940 High Performance Bi-color TOP LED

Bi-color LED of SMT830/940 consists of DDH AlGaAs and GaAs LEDs mounted on the lead frame as TOP LED package and is sealed with epoxy resin. It emits a spectral band of radiation at 830nm and 940nm at anode common.

◆ Specifications

1) Product Name	Bi-color TOP LED
2) Type No.	SMT830/940
3) Chip	
(1) Chip Material	AlGaAs/GaAs
(2) Peak Wavelength	830nm/940nm
4) Package	
(1) Lead Frame Die	Silver Plated
(2) Package Resin	PPA Resin
(3) Lens	Epoxy Resin

◆ Outer dimension (Unit: mm)

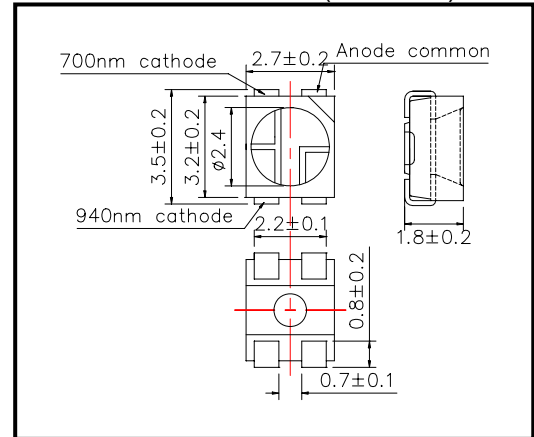

◆ Absolute Maximum Ratings

Item	Symbol	Maximum Rated Value		Unit	Ambient Temperature
		830nm	940nm		
Power Dissipation	P _D	90	80	mW	T _a =25°C
Forward Current	I _F	50	50	mA	T _a =25°C
Pulse Forward Current	I _{FP}	500	500	mA	T _a =25°C
Reverse Voltage	V _R	5		V	T _a =25°C
Operating Temperature	T _{OPR}	-20 ~ +80		°C	
Storage Temperature	T _{STG}	-30 ~ +80		°C	
Soldering Temperature	T _{SOL}	240		°C	

‡Soldering condition: Soldering condition must be completed within 3 seconds at 230°C

◆ Electro-Optical Characteristics [T_a=25°C]

Item	Symbol	Condition	Minimum		Typical		Maximum		Unit
			830nm	940nm	830nm	940nm	830nm	940nm	
Forward Voltage	V _F	I _F =50mA			1.60	1.30	1.80	1.40	V
Reverse Current	I _R	V _R =5V					10		uA
Total Radiated Power	P _O	I _F =50mA	5.0	5.0	10.0	7.5			mW
Peak Wavelength	λ _P	I _F =50mA	810	930	830	940	850	960	nm
Half Width	Δλ	I _F =50mA			40	50			nm
Viewing Half Angle	θ _{1/2}	I _F =50mA			±55				deg.

‡Total Radiated Power is measured by Photodyne #500

‡Brightness is measured by Tektronix J-16.