

## SMT700 High Performance Infrared TOP IR LED

SMT700 consists of an AlGaAs LED mounted on the lead frame as TOP LED package and is sealed with epoxy resin.  
It emits a spectral band of radiation at 700nm.

◆ Outer dimension (Unit: mm)

◆ Specifications

1) Product Name	TOP IR LED
2) Type No.	SMT700
3) Chip	
(1) Chip Material	AlGaAs
(2) Peak Wavelength	700nm typ.
4) Package	
(1) Lead Frame Die	Silver Plated
(2) Package Resin	PPA Resin
(3) Lens	Epoxy Resin

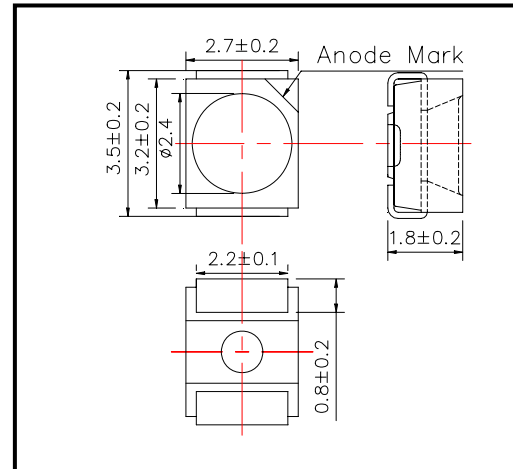

◆ Absolute Maximum Rating

Item	Symbol	Maximum Rated Value	Unit	Ambient Temperature
Power Dissipation	P <sub>D</sub>	100	mW	T <sub>a</sub> =25°C
Forward Current	I <sub>F</sub>	50	mA	T <sub>a</sub> =25°C
Pulse Forward Current	I <sub>FP</sub>	200	mA	T <sub>a</sub> =25°C
Reverse Voltage	V <sub>R</sub>	5	V	T <sub>a</sub> =25°C
Operating Temperature	T <sub>OPR</sub>	-20 ~ +80	°C	
Storage Temperature	T <sub>STG</sub>	-30 ~ +80	°C	
Soldering Temperature	T <sub>SOL</sub>	240	°C	

‡Pulse Forward Current condition: Duty=1% and Pulse Width=10us.

‡Soldering condition: Soldering condition must be completed within 3 seconds at 230°C

◆ Electro-Optical Characteristics [T<sub>a</sub>=25°C]

Item	Symbol	Condition	Minimum	Typical	Maximum	Unit
Forward Voltage	V <sub>F</sub>	I <sub>F</sub> =20mA		1.90	2.30	V
Reverse Current	I <sub>R</sub>	V <sub>R</sub> =5V			10	uA
Total Radiated Power	P <sub>O</sub>	I <sub>F</sub> =20mA	1.5	3.0		mW
Radiant Intensity	I <sub>E</sub>	I <sub>F</sub> =20mA	1.0	2.0		mW/sr
Peak Wavelength	λ <sub>P</sub>	I <sub>F</sub> =20mA		700		nm
Half Width	Δλ	I <sub>F</sub> =20mA		20		nm
Viewing Half Angle	θ <sub>1/2</sub>	I <sub>F</sub> =20mA		±55		deg.
Rise Time	t <sub>r</sub>	I <sub>F</sub> =20mA		80		ns
Fall Time	t <sub>f</sub>	I <sub>F</sub> =20mA		80		ns

‡Total Radiated Power is measured by Photodyne #500

‡Radiant Intensity is measured by Tektronix J-6512.