

SMT660/910-24 High Performance Bi-color TOP LED with Lens

Bi-color LED of SMT660/910-24 consists of AlGaAs LEDs mounted on the lead frame as TOP LED package with plastic ball lens.

It emits a spectral band of radiation at 650nm and 910nm at anode common.

◆ Specifications

- | | |
|---------------------|--------------------------|
| 1) Product Name | Bi-color TOP LED |
| 2) Type No. | SMT660/910-24 |
| 3) Chip | |
| (1) Chip Material | AlGaAs |
| (2) Peak Wavelength | 650nm/910nm |
| 4) Package | |
| (1) Lead Frame Die | Silver Plated |
| (2) Package Resin | PPA Resin |
| (3) Lens | Plastics Lens $\Phi 2.7$ |

◆ Outer dimension (Unit: mm)

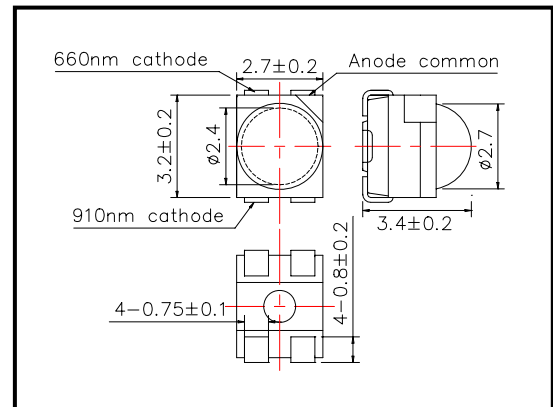

◆ Absolute Maximum Rating

Item	Symbol	Maximum Rated Value		Unit	Ambient Temperature
		660nm	910nm		
Power Dissipation	P _D	75	90	mW	T _a =25°C
Forward Current	I _F	30	50	mA	T _a =25°C
Reverse Voltage	V _R	5		V	T _a =25°C
Operating Temperature	T _{OPR}	-20 ~ +80		°C	
Storage Temperature	T _{STG}	-30 ~ +80		°C	
Soldering Temperature	T _{SOL}	240		°C	

‡Soldering condition: Soldering condition must be completed within 3 seconds at 230°C

◆ Electro-Optical Characteristics [T_a=25°C]

Item	Symbol	Condition	Minimum		Typical		Maximum		Unit
			660nm	910nm	660nm	910nm	660nm	910nm	
Forward Voltage	V _F	I _F =20mA			1.90	1.30	2.20	1.50	V
Reverse Current	I _R	V _R =5V					10		uA
Total Radiated Power	P _O	I _F =20mA	1.5	1.5	2.5	2.5			mW
Radiant Intensity	I _E	I _F =20mA			4	5			mW/sr
Peak Wavelength	λ _P	I _F =20mA	640	900	650	910	660	930	nm
Half Width	Δλ	I _F =20mA			20	60			nm
Viewing Half Angle	θ _{1/2}	I _F =20mA			±20				deg.

‡Total Radiated Power is measured by Photodyne #500

‡Radiant Intensity is measured by Tektronix J-6512.