

SMT660/870-24 High Performance Bi-color TOP LED with Lens

Bi-color LED of SMT660/870-24 consists of AlGaAs LEDs mounted on the lead frame as TOP LED package with plastic ball lens.

It emits a spectral band of radiation at 650nm and 870nm at anode common.

◆ Outer dimension (Unit: mm)

◆ Specifications

- 1) Product Name Bi-color TOP LED
- 2) Type No. SMT660/870-24
- 3) Chip
- (1) Chip Material AlGaAs
- (2) Peak Wavelength 650nm/870nm
- 4) Package
- (1) Lead Frame Die Silver Plated
- (2) Package Resin PPA Resin
- (3) Lens Plastics Lens $\Phi 2.7$

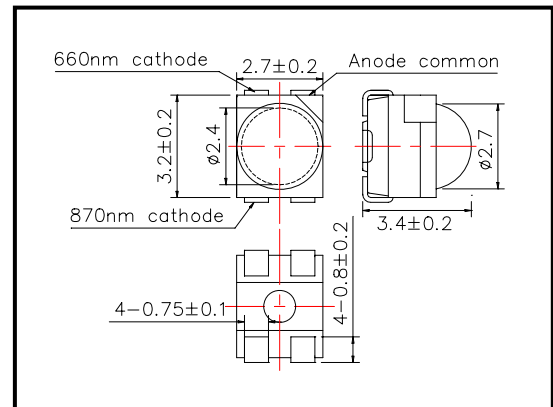

◆ Absolute Maximum Rating

Item	Symbol	Maximum Rated Value		Unit	Ambient Temperature
		660nm	870nm		
Power Dissipation	P _D	75	160	mW	T _a =25°C
Forward Current	I _F	30	100	mA	T _a =25°C
Reverse Voltage	V _R	5		V	T _a =25°C
Operating Temperature	T _{OPR}	-20 ~ +80		°C	
Storage Temperature	T _{STG}	-30 ~ +80		°C	
Soldering Temperature	T _{SOL}	240		°C	

‡Soldering condition: Soldering condition must be completed within 3 seconds at 230°C

◆ Electro-Optical Characteristics [T_a=25°C]

Item	Symbol	Condition	Minimum		Typical		Maximum		Unit
			660nm	870nm	660nm	870nm	660nm	870nm	
Forward Voltage	V _F	I _F =20mA			1.90	1.35	2.20	1.55	V
Reverse Current	I _R	V _R =5V					10		uA
Total Radiated Power	P _O	I _F =20mA	1.5	3.0	2.5	5.0			mW
Radiant Intensity	I _E	I _F =20mA			4.0	10.0			mW/sr
Peak Wavelength	λ _P	I _F =20mA	640	850	650	870	660	880	nm
Half Width	Δλ	I _F =20mA			20	40			nm
Viewing Half Angle	θ _{1/2}	I _F =20mA			±20				deg.

‡Total Radiated Power is measured by Photodyne #500

‡Radiant Intensity is measured by Tektronix J-6512.