

SMC565 High Bright Green color SMD LED on ceramics

SMC565 consists of a GaP LED mounted on the ceramics package and is sealed with silicone or epoxy resin.

It emits a spectral band of radiation at 565nm.

◆Outer dimension (Unit : mm)

◆Specifications

- | | |
|---------------------|--------------------------|
| 1) Product Name | SMD type green color LED |
| 2) Type No. | SMC565 |
| 3) Chip | |
| (1) Chip Material | GaP |
| (2) Peak Wavelength | 565nm typ. |
| 4) Package | |
| (1) Package | Ceramics |
| (2) Lens | Silicone or Epoxy resin |

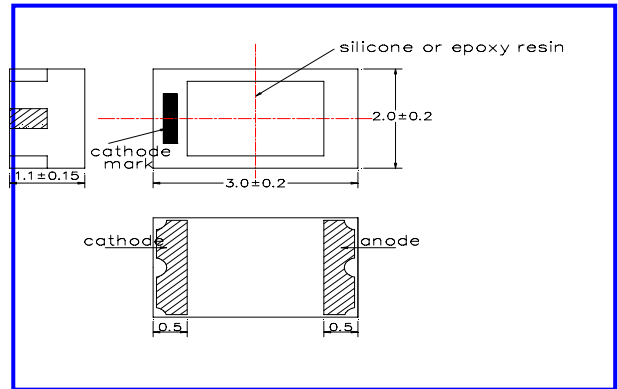

◆Absolute Maximum Rating

Item	Symbol	Maximum Rated Value	Unit	Ambient Temperature
Power Dissipation	P _D	130	mW	T _a =25°C
Forward Current	I _F	50	mA	T _a =25°C
Reverse Voltage	V _R	5	V	T _a =25°C
Operating Temperature	T _{OPR}	-20 ~ +80	°C	
Storage Temperature	T _{STG}	-30 ~ +80	°C	
Soldering Temperature	T _{SOL}	240	°C	

‡Soldering condition : Solder condition must be completed within 3 seconds at 240°C

◆Electro-Optical Characteristics [T_a=25°C]

Item	Symbol	Condition	Minimum	Typical	Maximum	Unit
Forward Voltage	V _F	I _F =20mA		2.2	2.4	V
Reverse Current	I _R	V _R =5V			10	uA
Total Radiated Power	P _O	I _F =20mA		0.1		mW
Brightness	I _v	I _F =20mA		30		mcd
Radiant Intensity	I _E	I _F =20mA		0.03		mW/sr
Peak Wavelength	λ _P	I _F =20mA	560	565	570	nm
Half Width	Δλ	I _F =20mA		25		nm
Viewing Half Angle	Δθ	I _F =20mA		±55		deg.

‡Total Radiated Power is measured by Photodyne #500

‡Radiant Intensity is measured by Tektronix J-6512.

‡Brightness is measured by Tektronix J-16.