

SMB940-1100-03 High Power type Top LED with Lens

SMB940-1100-03 is an AlGaAs LED mounted on copper heat sink with a 5*5 mm package and molded with super beam lens. On forward bias, it emits a band of radiation which peaks 940nm. These devices are intended to be operated at pulsed current of 4A under maximum 2.6V for stable long life.

◆ Specifications

- 1) Product Name Super Flux mold type LED
- 2) Type No. SMB940-1100-03
- 3) Chip
 - (1) Chip Material GaAs
 - (2) Chip Dimension 1000um*1000um
 - (3) Peak Wavelength 940nm typ.
- 4) Package
 - (1) Type Super Beam type LED
 - (2) Resin Material Epoxy Resin
 - (3) Lead Frame Silver Plated Copper

◆ Outer dimension (Unit: mm)

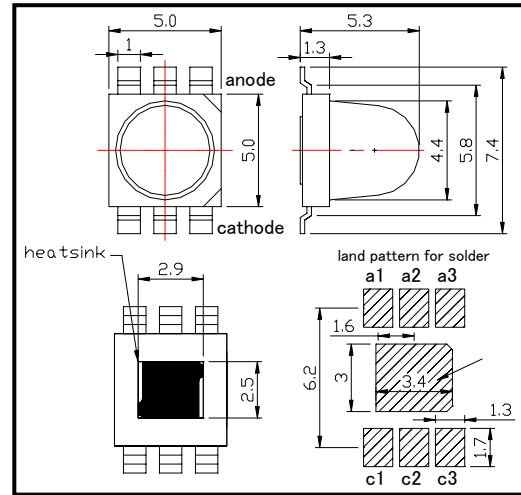

◆ Absolute Maximum Ratings

Item	Symbol	Maximum Rated Value	Unit	Ambient Temperature
Power Dissipation	PD	900	mW	Ta=25°C
Forward Current	IF	600	mA	Ta=25°C
Pulse Forward Current	IFP	4000	mA	Ta=25°C
Reverse Voltage	VR	10	V	Ta=25°C
Operating Temperature	TOPR	-30 ~ +85	°C	
Storage Temperature	TSTG	-30 ~ +100	°C	
Soldering Temperature	TSOL	265	°C	

‡Pulse Forward Current condition: Duty=1% and Pulse Width=10us.

‡Soldering condition: Soldering condition must be completed within 3 seconds at 265°C

◆ Electro-Optical Characteristics [Ta=25°C]

Item	Symbol	Condition	Minimum	Typical	Maximum	Unit
Forward Voltage	VF	IF=200mA		1.25	1.5	V
Pulsed Forward Voltage	VF	IFP=4A		2.6	3.5	V
Reverse Current	IR	VR=10V			10	uA
Total Radiated Power	PO	IF=200mA	20.0	35.0		mW
Radiant Intensity	IE	IF=200mA		40		mW/sr
Peak Wavelength	λP	IF=50mA		940		nm
Half Width	Δλ	IF=50mA		60		nm
Viewing Half Angle	θ 1/2	IF=50mA		± 12		deg.
Rise Time	tr	IF=50mA		1000		ns
Fall Time	tf	IF=50mA		500		ns

‡Total Radiated Power is measured by Photodyne #500

‡Radiant Intensity is measured by Tektronix J-6512.