

SMB470-1100-03 High Power type Top LED with Lens

SMB470-1100-03 is an InGaN LED mounted on copper heat sink with a 5x5 mm package and molded with super beam lens. On forward bias, it emits a band of visible light which peaks 470nm. It is 16000mcd typical of brightness and $\pm 10^\circ$ of viewing half angle.

◆ Specifications

- 1) Product Name Super Flux mold type LED
- 2) Type No. SMB470-1100-03
- 3) Chip
 - (1) Chip Material InGaAs
 - (2) Chip Dimension 1000um*1000um
 - (3) Peak Wavelength 470nm typ.
- 4) Package
 - (1) Type Super Beam type LED
 - (2) Resin Material Epoxy Resin
 - (3) Lead Frame Silver Plated Copper

◆ Outer dimension (Unit: mm)

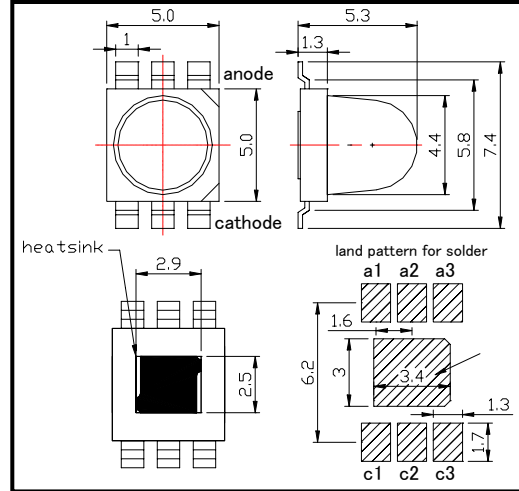

◆ Absolute Maximum Ratings

Item	Symbol	Maximum Rated Value	Unit	Ambient Temperature
Power Dissipation	PD	1000	mW	Ta=25°C
Forward Current	IF	350	mA	Ta=25°C
Pulse Forward Current	IFP	700	mA	Ta=25°C
Reverse Voltage	VR	10	V	Ta=25°C
Operating Temperature	TOPR	-30 ~ +85	°C	
Storage Temperature	TSTG	-30 ~ +100	°C	
Soldering Temperature	TSOL	265	°C	

‡Pulse Forward Current condition: Duty=1% and Pulse Width=10us.

‡Soldering condition: Soldering condition must be completed within 3 seconds at 265°C

◆ Electro-Optical Characteristics [Ta=25°C]

Item	Symbol	Condition	Minimum	Typical	Maximum	Unit
Forward Voltage	VF	IF=200mA		3.4	4.0	V
Pulsed Forward Voltage	VF	IFP=0.5A		3.8	4.5	V
Reverse Current	IR	VR=10V			10	uA
Total Radiated Power	PO	IF=200mA		80		mW
Brightness	Ie	IF=200mA		16000		mcd
Peak Wavelength	λP	IF=50mA		470		nm
Half Width	$\Delta\lambda$	IF=50mA		17		nm
Viewing Half Angle	$\theta 1/2$	IF=50mA		± 10		deg.
Rise Time	tr	IF=50mA		200		ns
Fall Time	tf	IF=50mA		150		ns

‡Total Radiated Power is measured by Photodyne #500

‡Brightness is measured by Tektronix J-6512.