

## PD018T52 Stem type photo-diode

PD018T52 is a PIN-photodiode featuring excellent responsivity and high photocurrent. This PIN-photodiode consists of a large chip with 1.6x1.6mm active area mounted on the TO-18 stem and is hermetical sealed by metal can with flat lens. These devices are designed to be easy of setting up optically with a wide angle of half sensitivity of  $\pm 45^\circ$

### ◆ Specifications

1) Product Name	Stem Type Photo-Diode
2) Type No.	PD018T52
3) Chip	
(1) Chip Size	1.8mmx1.8mm
(2) Active Area	1.6mmx1.6mm
4) Package	
(1) Type	TO-18
(2) Lens	Glass Flat Lens
(3)Cap	Gold Plated

### ◆ Outer dimension (Unit: mm)

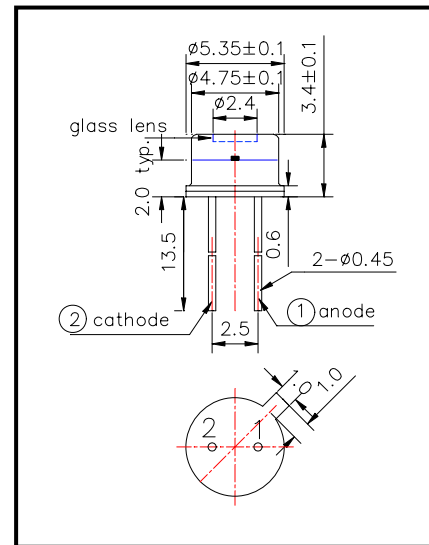

### ◆ Absolute Maximum Ratings [Ta=25°C]

Item	Symbol	Maximum Rated Value	Unit
Reverse Breakdown Voltage	$V_{(BR)R}$	170	V
Operating Temperature	$T_{OPR}$	-25 ~ +100	°C
Storage Temperature	$T_{STG}$	-30 ~ +125	°C
Soldering Temperature	$T_{SOL}$	240	°C

‡Soldering condition: Soldering condition must be completed within 2 seconds at 240°C

### ◆ Electro-Optical Characteristics [Ta=25°C]

Item	Symbol	Condition	Minimum	Typical	Maximum	unit
Reverse Photo Current	$I_L$	$V_R=10V, L=1000Lx$		15		uA
Reverse Dark Current	$I_D$	$V_R=10V$			10	nA
Open Circuit Voltage	$V_{OC}$	$V_R=10V, L=1000Lx$		410		mV
Spectral Responsivity (Peak)	$\lambda_P$			900		nm
Half Angle of Sensitivity	$\theta_{1/2}$			$\pm 45$		deg.
Total Capacitance	$C_T$	$V_R=10V, f=1MHz$		18		pF
Rise/Fall Time(10%~90%)	$t_r$	$R_L=1K\Omega, V_R=10V$		30		ns
	$t_f$			30		ns