

# L940-\_\_ \_V

## Infrared LED Lamp

This series of L940-\_\_ \_V is a GaAs LED mounted on a lead frame and encapsulated in various types of epoxy lens which offer different design settings.

On forward bias, it emits a high power radiation of typical 18mW with a peak wavelength at 940nm.

### Specifications

- |                    |             |
|--------------------|-------------|
| 1. Chip material   | GaAs        |
| 2. Peak wavelength | 940nm       |
| 3. Resin Material  | Epoxy resin |
| 4. Solder          | Lead free   |



### Absolute Maximum Ratings

Item	Symbol	Maximum Rated Value	Unit	Ambient Temperature
Power Dissipation	$P_D$	160	mW	$T_a=25^{\circ}\text{C}$
Forward Current	$I_F$	100	mA	$T_a=25^{\circ}\text{C}$
Pulse Forward Current	$I_{FP}$	1000	mA	$T_a=25^{\circ}\text{C}$
Reverse Voltage	$V_R$	5	V	$T_a=25^{\circ}\text{C}$
Operating Temperature	$T_{OPR}$	-30 ~ +85	$^{\circ}\text{C}$	$T_a=25^{\circ}\text{C}$
Storage Temperature	$T_{STG}$	-40 ~ +100	$^{\circ}\text{C}$	
Soldering Temperature	$T_{SOL}$	265	$^{\circ}\text{C}$	

### Electro-Optical Characteristics ( $T_a=25^{\circ}\text{C}$ )

Item	Symbol	Condition	Minimum	Typical	Maximum	Unit
Forward Voltage	$V_F$	$I_F=50\text{mA}$		1.3	1.5	V
Reverse Current	$I_R$	$V_R=5\text{V}$			10	$\mu\text{A}$
Total Radiated Power	$P_O$	$I_F=50\text{mA}$	13	18		mW
Peak Wavelength	$\lambda_P$	$I_F=50\text{mA}$		940		nm
Half Width	$\Delta\lambda$	$I_F=50\text{mA}$		50		nm
Rise Time	$t_r$	$I_F=50\text{mA}$		2500		ns
Fall Time	$t_f$	$I_F=50\text{mA}$		1000		ns

**Characteristics of Radiant Intensity (Ta=25°C)**

Type	Viewing Half Angle	Radiant Intensity I <sub>F</sub> =50mA Unit : mW/sr			Outer Dimension	Dimension Figure
		Minimum	Typical	Maximum		
L940-01V	±10°		55		Φ5	1
L940-02V	±7°		85		Φ5	2
L940-03V	±10°		55		Φ5	3
L940-04V	±20°		25		Φ5	4
L940-05V	±40°		7		Φ5	5
L940-06V	±7°		90		Φ5	6
L940-09V	±25°(Long) ±15°(Short)		30		Φ5 Oval	7
L940-46V					Φ5	8
L940-41V	±16°		30		Φ4	9
L940-42V	±23°		25		Φ4	10
L940-31V					Φ3	11
L940-33V	±18°		20		Φ3	12
L940-34V					Φ3	13
L940-36V	±33°		10		Φ3	14

Brightness is measured by Tektronix J-16

Total Radiant Power is measured by Photodyne #500

Outer Dimension of LED Lamp

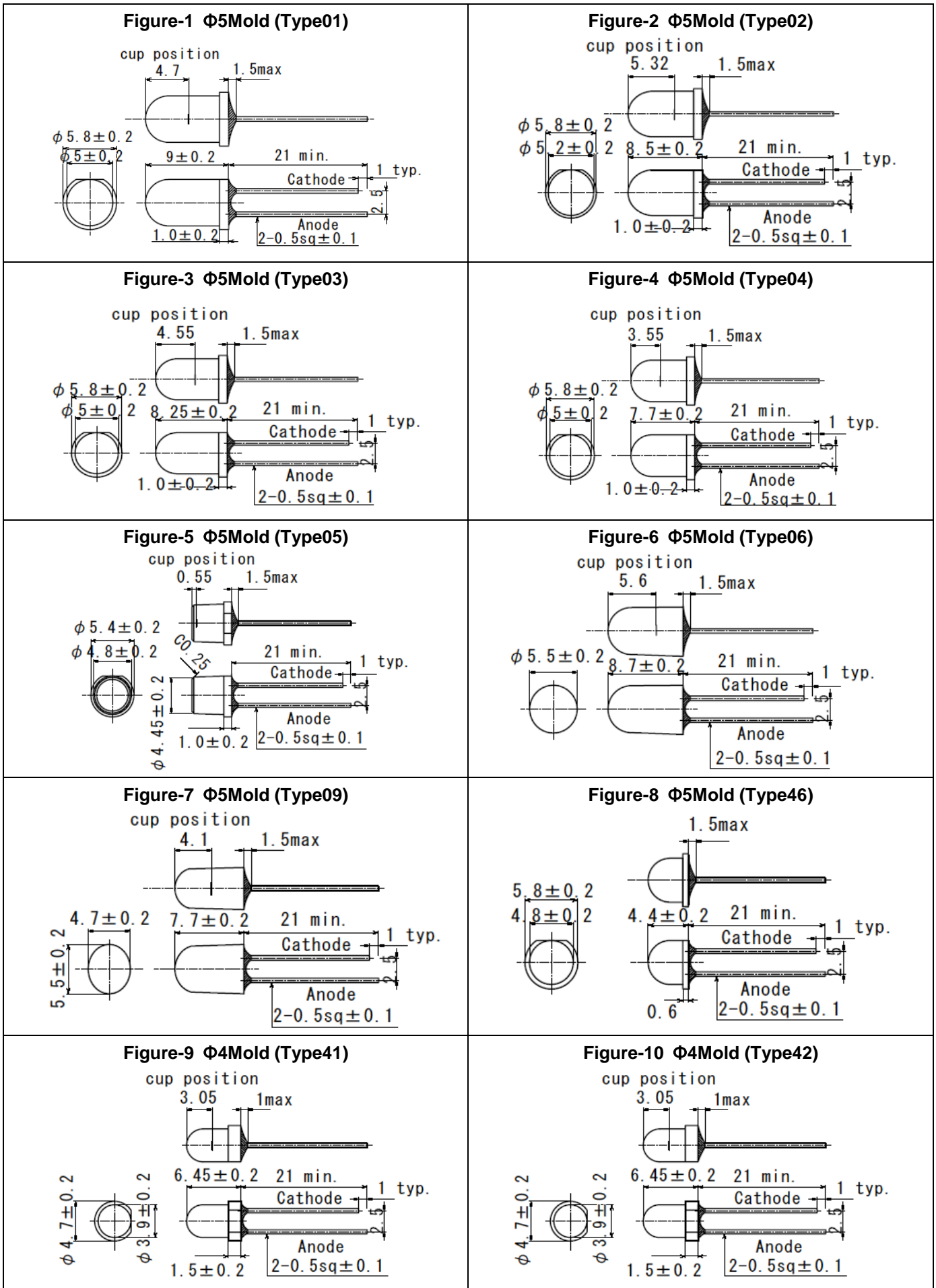

**Outer Dimension of LED Lamp**

<p><b>Figure-11 <math>\Phi 3</math>Mold (Type31)</b> cup position</p> <p>0.37 1max  <math>\phi 3.6 \pm 0.2</math>  <math>\phi 3 \pm 0.2</math>  <math>3.5 \pm 0.2</math> 21 min. 1 typ.          Cathode          Anode  <math>2-0.5sq \pm 0.1</math>          1.5 typ.</p>	<p><b>Figure-12 <math>\Phi 3</math>Mold (Type33)</b> cup position</p> <p>2.65 1max  <math>\phi 3.8 \pm 0.2</math>  <math>\phi 3 \pm 0.2</math>  <math>5.3</math> 21 min. 1 typ.          Cathode          Anode  <math>2-0.5sq \pm 0.1</math>          0.8 typ.</p>
<p><b>Figure-13 <math>\Phi 3</math>Mold (Type34)</b> cup position</p> <p>3.25 1max  <math>\phi 3.8 \pm 0.2</math>  <math>\phi 3 \pm 0.2</math>  <math>5.3 \pm 0.2</math> 21 min. 1 typ.          Cathode          Anode  <math>2-0.5sq \pm 0.1</math>          1.5 typ.</p>	<p><b>Figure-14 <math>\Phi 3</math>Mold (Type36)</b> cup position</p> <p>2.1 1max  <math>\phi 4 \pm 0.2</math>  <math>\phi 3 \pm 0.2</math>  <math>5.3 \pm 0.2</math> 21 min. 1 typ.          Cathode          Anode  <math>2-0.5sq \pm 0.1</math>  <math>2 \pm 0.4</math></p>
<p><b>Figure-15</b></p>	<p><b>Figure-16</b></p>
<p><b>Figure-17</b></p>	<p><b>Figure-18</b></p>
<p><b>Figure-19</b></p>	<p><b>Figure-20</b></p>

The Viewing half angle

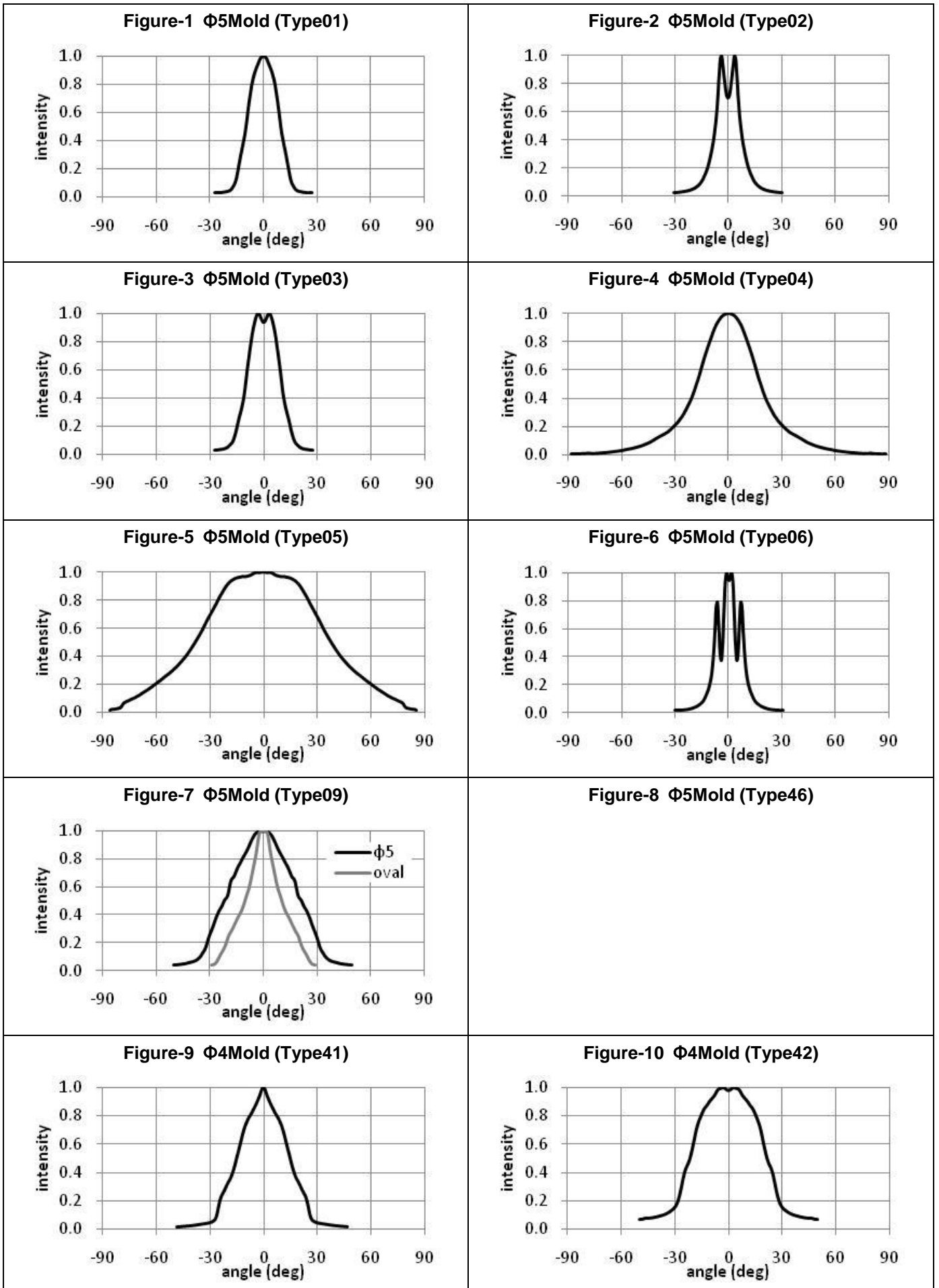

The Viewing half angle

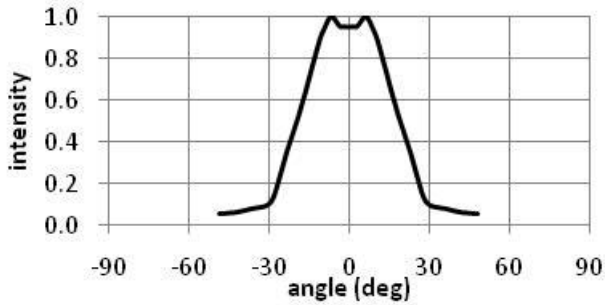
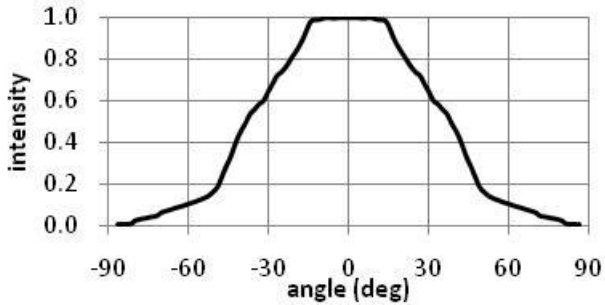
<p><b>Figure-11 <math>\Phi</math>3Mold (Type31)</b></p>	<p><b>Figure-12 <math>\Phi</math>3Mold (Type33)</b></p> 
<p><b>Figure-13 <math>\Phi</math>3Mold (Type34)</b></p>	<p><b>Figure-14 <math>\Phi</math>3Mold (Type36)</b></p> 
<p><b>Figure-15</b></p>	<p><b>Figure-16</b></p>
<p><b>Figure-17</b></p>	<p><b>Figure-18</b></p>
<p><b>Figure-19</b></p>	<p><b>Figure-20</b></p>

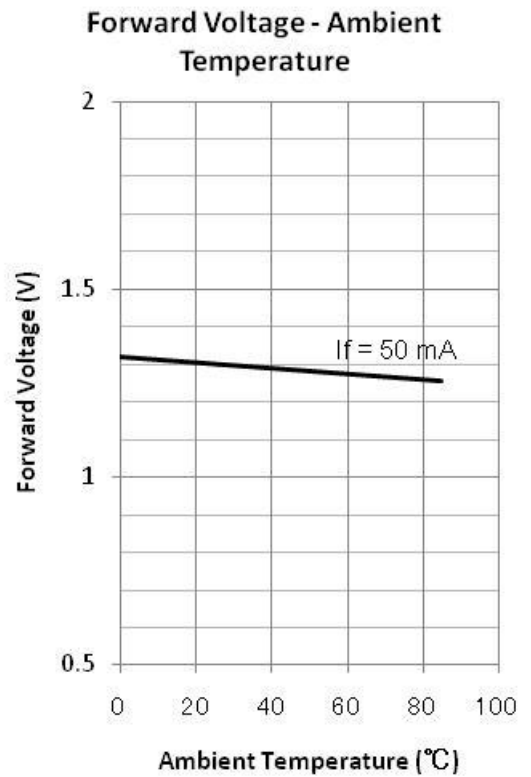
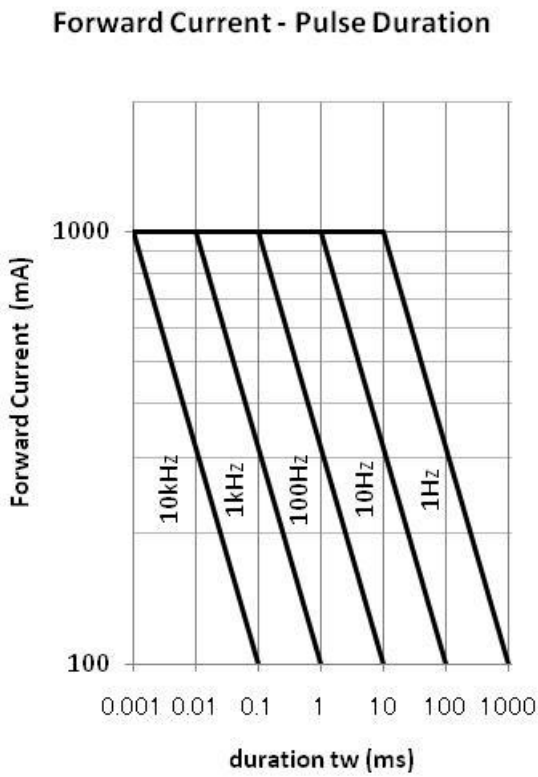
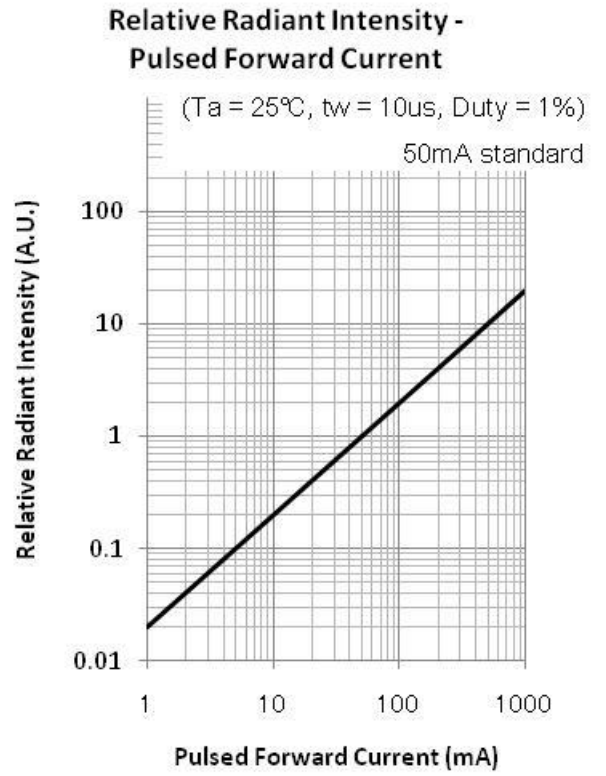
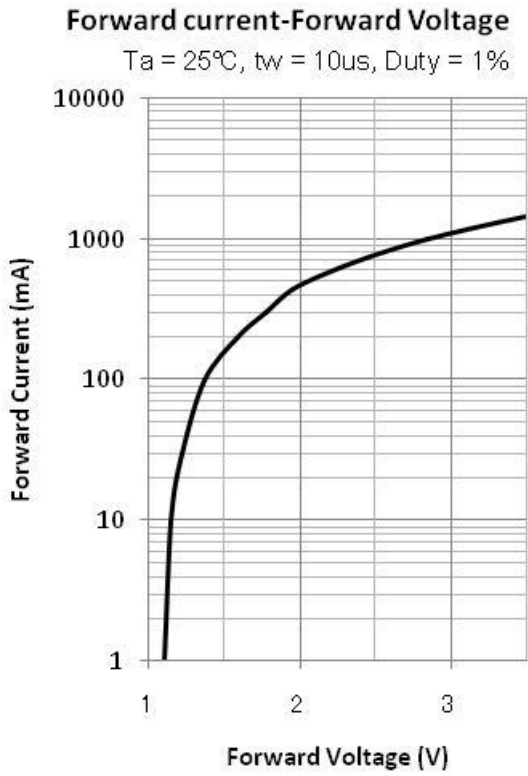

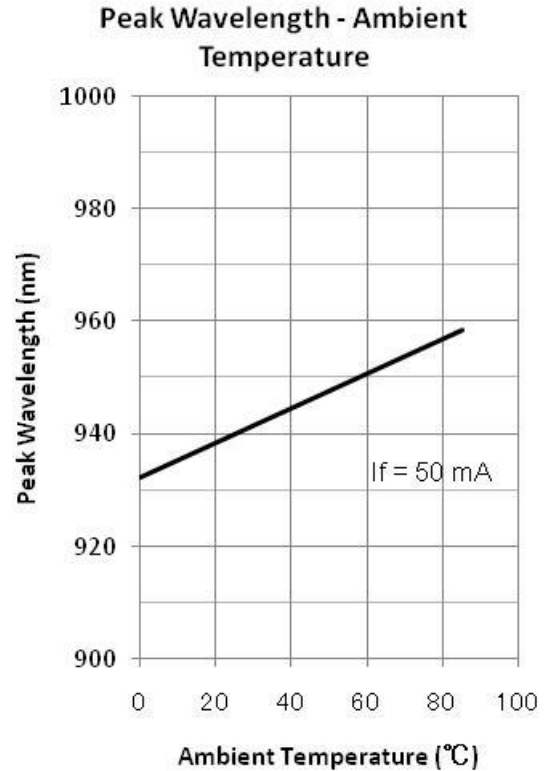
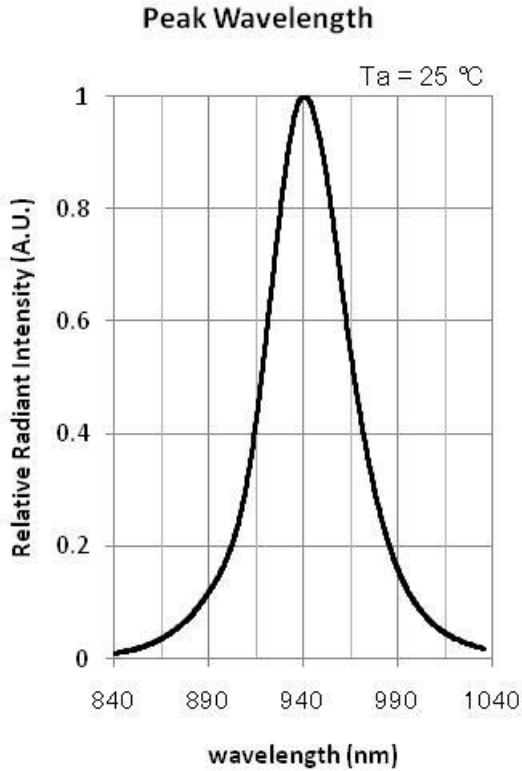
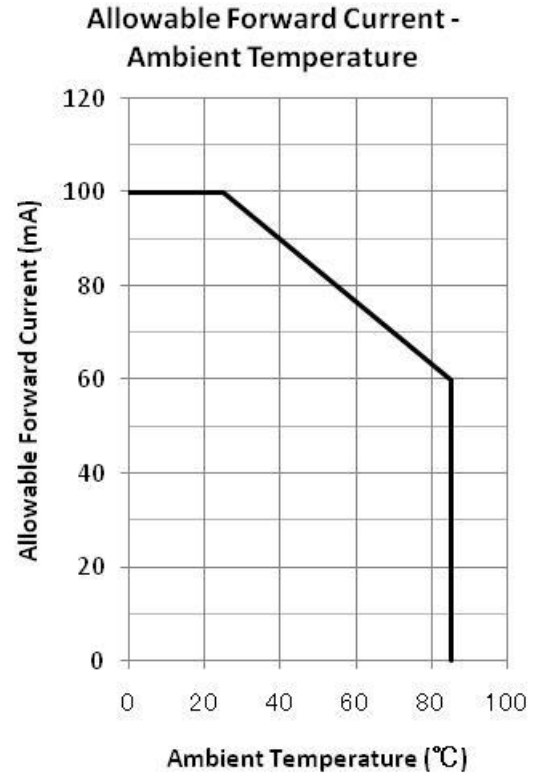
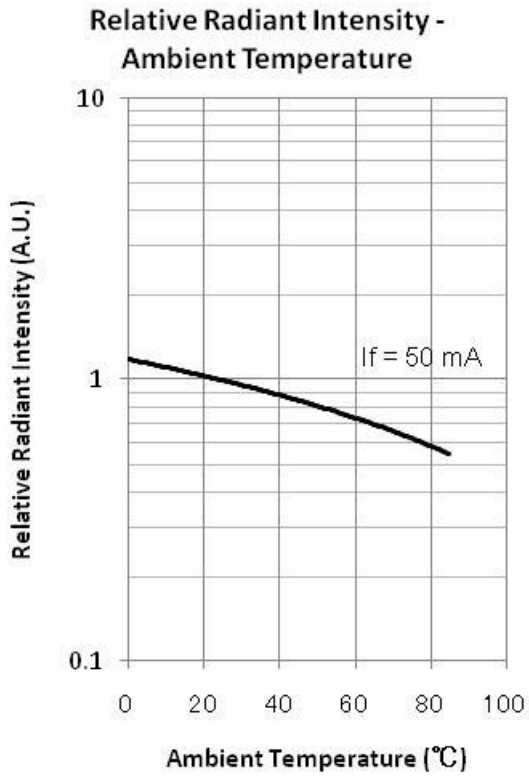

**Recommended Land Layout (unit: mm)**

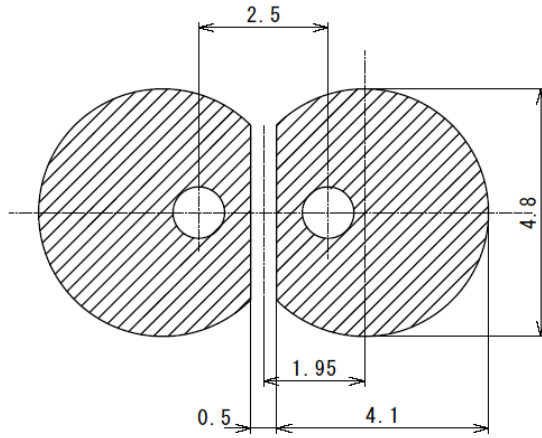

**Soldering Conditions**

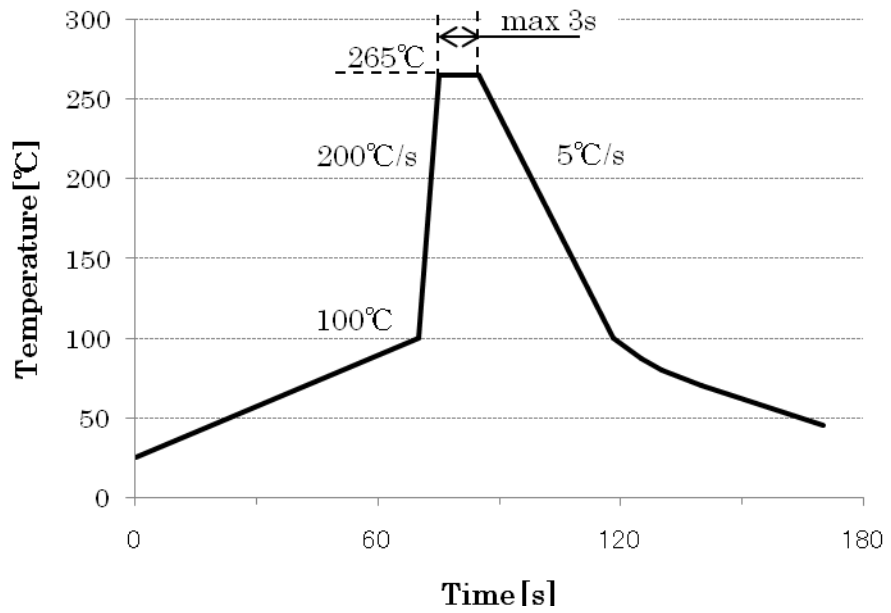

**Marubeni America Corporation**

3945 Freedom Circle, Suite 1000, Santa Clara, CA 95054 408-330-0650 (Ext. 330), 408-330-0655 (Fax), [sales@tech-led.com](mailto:sales@tech-led.com)