

L870-66-60 epoxy lens type Infrared illuminator

L870-66-60 is a wide viewing and extremely high output power illuminator assembled with a total of 60 high efficiency AlGaAs diode chips, mounted on a metal stem TO-66 with AlN ceramics and covered with double coated clear silicone and epoxy resin. These devices are designed for high current operation with proper heat sinking to improve thermal conductive efficiency.

◆ Features

- 1) High reliability
- 2) Compact (TO-66) package
- 3) High output power at 870nm

◆ Applications

- 1) For IR search light
- 2) For CCD lighting
- 3) For night vision light source

◆ Specifications

- 1) Product name IR illuminator
- 2) Spec. No. L870-66-60
- 3) Chip
 - (1) Material AlGaAs
 - (2) Peak wavelength 870m
- 4) Package
 - (1) Stem TO-66 stem with AlN
 - (2) Lens Clear silicone and epoxy lens

◆ Outer dimension (Unit: mm)

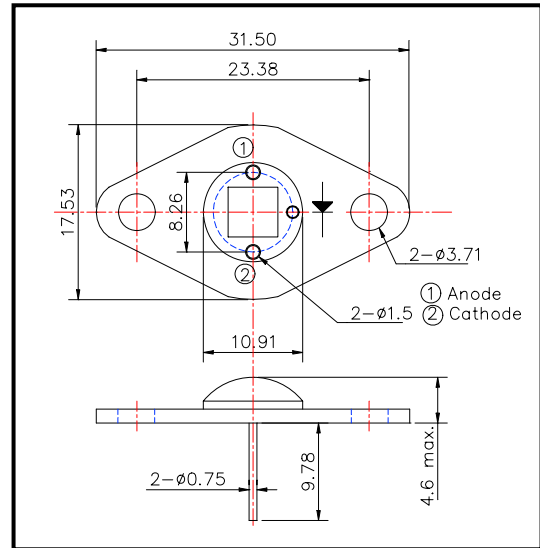

◆ Absolute Maximum Ratings

Item	Symbol	Maximum Rated Value	Unit	Ambient Temp.
Power Dissipation	PD	7.5	W	Ta=25°C
Forward Current	IF	1.2	A	Ta=25°C
Pulse Forward Current	IFP	6	A	Ta=25°C
Reverse Voltage	VR	50	V	Ta=25°C
Operating Temperature	TOPR	-30 ~ +80	°C	
Storage Temperature	TSTG	-30 ~ +110	°C	
Soldering Temperature	TSOL	240	°C	

‡Pulse Forward Current condition: Duty=1% and Pulse Width=1us.

‡Soldering condition: Soldering condition must be completed within 3 seconds at 260°C

◆ Electro-Optical Characteristics

Item	Symbol	Condition	Minimum	Typical	Maximum	Unit
Total Radiated Power	PO	IF=800mA		1600		mW
Total Radiated Power	PO	IF=5A		9500		mW
Radiant Intensity	IE	IF=800mA		450		mW/sr
Forward Voltage	VF	IF=800mA		7.50		V
Reverse Current	VR	IR=10uA	50			V
Peak Wavelength	λP	IF=800mA	860	870	880	nm
Half Width	Δλ	IF=800mA		40		nm
Viewing Half Angle	θ 1/2	IF=800mA		±60		deg.
Rise Time	tf	IF=100mA		15		ns
Fall Time	tf	IF=100mA		10		ns

‡Heat sink is required thermal resistance <8K/W