

# L830N-04CU Infrared LED Lamp

L830N-04CU is an AlGaAs LED mounted on a lead frame with a clear epoxy lens and is 46mW typ. of output power and 200mW/sr typ. of radiant intensity.

On forward bias it emits a spectral band of radiation, which peaks at 810nm.

◆ Specifications

- 1) Product Name      Infrared LED Lamp
- 2) Type No.          L830N-04CU
- 3) Chip
- (1) Chip Material      AlGaAs
- (2) Peak Wavelength   810nm typ.
- 4) Package
- (1) Type                Φ5mm clear molding
- (2) Resin Material      Epoxy Resin
- (3) Lead Frame        Soldered

◆ Outer dimension (Unit: mm)

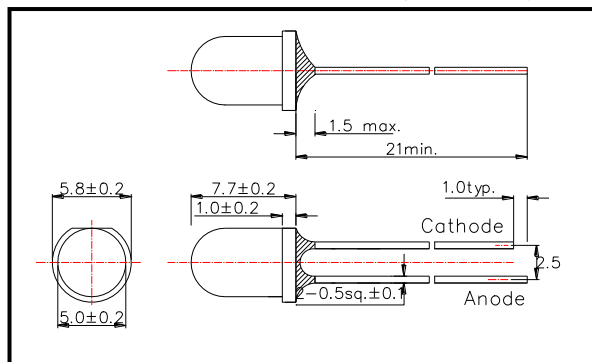

◆ Absolute Maximum Ratings

Item	Symbol	Maximum Rated Value	Unit	Ambient Temperature
Power Dissipation	P <sub>D</sub>	170	mW	T <sub>a</sub> =25°C
Forward Current	I <sub>F</sub>	100	mA	T <sub>a</sub> =25°C
Pulse Forward Current	I <sub>FP</sub>	1000	mA	T <sub>a</sub> =25°C
Reverse Voltage	V <sub>R</sub>	5	V	T <sub>a</sub> =25°C
Junction Temperature	T <sub>J</sub>	100	°C	
Thermal Resistance	R <sub>thjp</sub>	160	K/W	
Operating Temperature	T <sub>OPR</sub>	-30 ~ +85	°C	
Storage Temperature	T <sub>STG</sub>	-30 ~ +100	°C	
Soldering Temperature	T <sub>SOL</sub>	265	°C	

‡Pulse Forward Current condition: Duty=1% and Pulse Width=10us.

‡Soldering condition: Soldering condition must be completed within 3 seconds at 265°C

‡Thermal resistance: junction – ambient, leads 7mm, soldered on PCB

◆ Electro-Optical Characteristics [T<sub>a</sub>=25°C]

Item	Symbol	Condition	Minimum	Typical	Maximum	Unit
Forward Voltage	V <sub>F</sub>	I <sub>F</sub> =50mA DC		1.50	1.70	V
		I <sub>F</sub> =100mA, t <sub>p</sub> =20ms		1.60	1.9	
Reverse Current	I <sub>R</sub>	V <sub>R</sub> =5V			10	uA
Total Radiated Power	P <sub>O</sub>	I <sub>F</sub> =50mA DC	18.0	23.0		mW
		I <sub>F</sub> =100mA, t <sub>p</sub> =20ms		46.0		
Radiant Intensity	I <sub>E</sub>	I <sub>F</sub> =50mA DC		55		mW/sr
		I <sub>F</sub> =100mA, t <sub>p</sub> =20ms		110		
Peak Wavelength	λ <sub>P</sub>	I <sub>F</sub> =50mA	820	830	840	nm
Half Width	Δλ	I <sub>F</sub> =50mA		35		nm
Viewing Half Angle	θ <sub>1/2</sub>	I <sub>F</sub> =50mA		±16		deg.
Rise Time	t <sub>r</sub>	I <sub>F</sub> =50mA		20		ns
Fall Time	t <sub>f</sub>	I <sub>F</sub> =50mA		15		ns

‡Total Radiated Power is measured by Photodyne #500

‡Radiant Intensity is measured by Tektronix J-6512

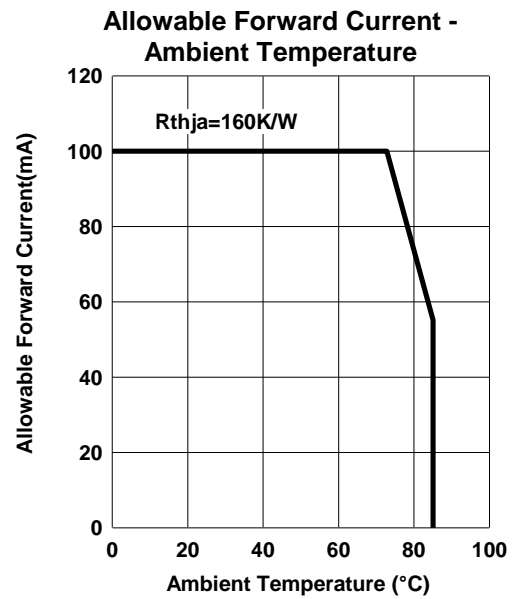
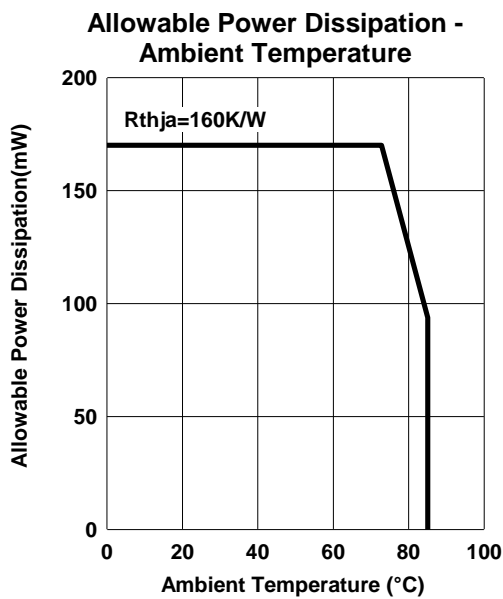
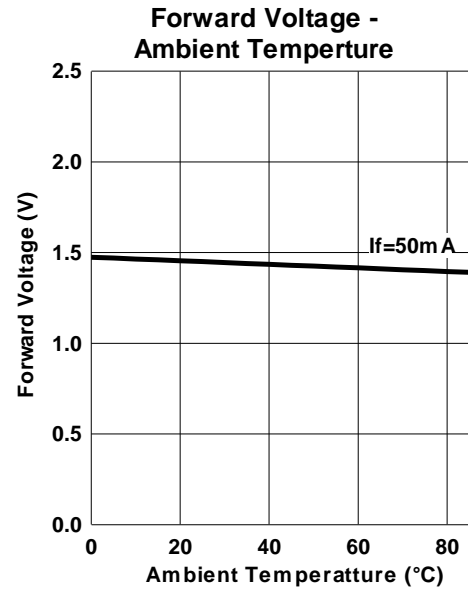
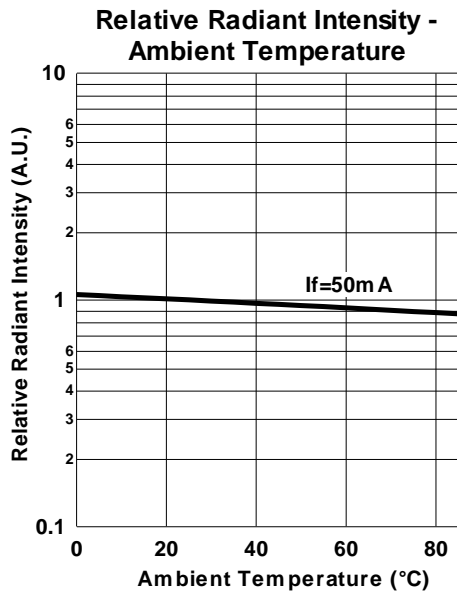
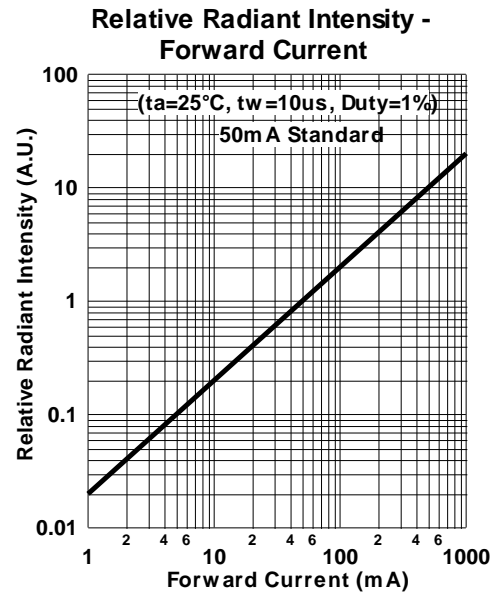
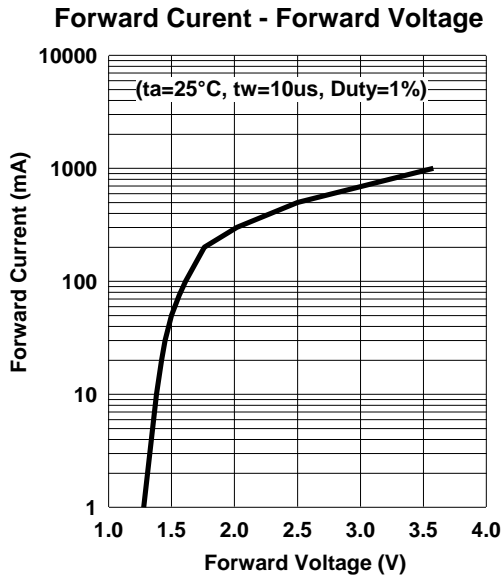

**Relative Spectral Emission**

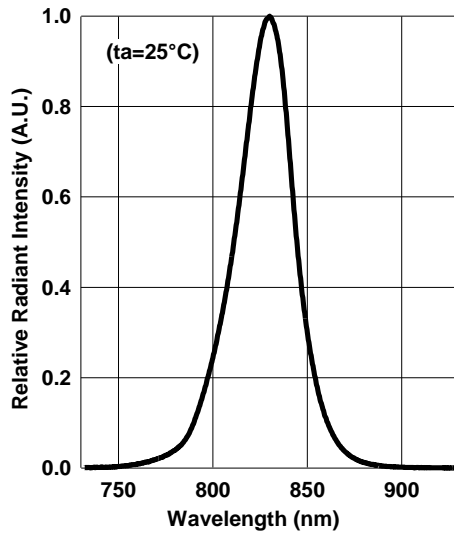

**Peak Wavelength - Ambient Temperature**

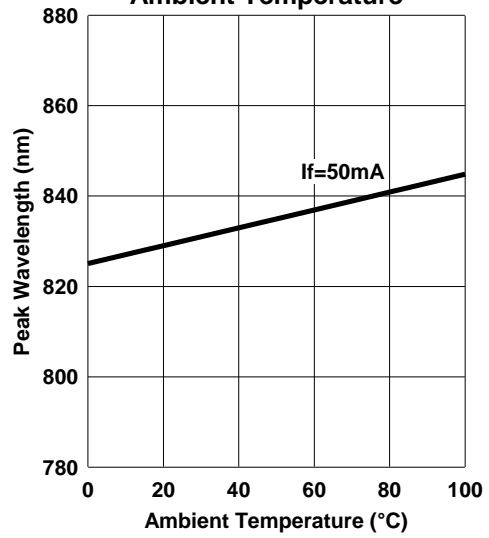

**Radiation Characteristics**

