

# L830-\_\_ \_AU

## Infrared LED Lamp

This series of L830-\_\_ \_AU is an AlGaAs LED mounted on a lead frame and encapsulated in various types of epoxy lens which offer different design settings.

On forward bias, it emits a high power radiation of typical 18mW with a peak wavelength at 830nm.

### Specifications

- |                    |             |
|--------------------|-------------|
| 1. Chip material   | AlGaAs      |
| 2. Peak wavelength | 830nm       |
| 3. Resin Material  | Epoxy resin |
| 4. Solder          | Lead free   |



### Absolute Maximum Ratings

Item	Symbol	Maximum Rated Value	Unit	Ambient Temperature
Power Dissipation	$P_D$	170	mW	$T_a=25^{\circ}\text{C}$
Forward Current	$I_F$	100	mA	$T_a=25^{\circ}\text{C}$
Pulse Forward Current	$I_{FP}$	500	mA	$T_a=25^{\circ}\text{C}$
Reverse Voltage	$V_R$	5	V	$T_a=25^{\circ}\text{C}$
Operating Temperature	$T_{OPR}$	-30 ~ +85	$^{\circ}\text{C}$	$T_a=25^{\circ}\text{C}$
Storage Temperature	$T_{STG}$	-40 ~ +100	$^{\circ}\text{C}$	
Soldering Temperature	$T_{SOL}$	265	$^{\circ}\text{C}$	

### Electro-Optical Characteristics ( $T_a=25^{\circ}\text{C}$ )

Item	Symbol	Condition	Minimum	Typical	Maximum	Unit
Forward Voltage	$V_F$	$I_F=50\text{mA}$		1.6	1.8	V
Reverse Current	$I_R$	$V_R=5\text{V}$			10	$\mu\text{A}$
Total Radiated Power	$P_O$	$I_F=50\text{mA}$	16.0	18.0		mW
Peak Wavelength	$\lambda_P$	$I_F=50\text{mA}$		830		nm
Half Width	$\Delta\lambda$	$I_F=50\text{mA}$		35		nm
Rise Time	$t_r$	$I_F=50\text{mA}$		50		ns
Fall Time	$t_f$	$I_F=50\text{mA}$		25		ns

**Characteristics of Radiant Intensity (Ta=25°C)**

Type	Viewing Half Angle	Radiant Intensity I <sub>F</sub> =50mA Unit : mW/sr			Outer Dimension	Dimension Figure
		Minimum	Typical	Maximum		
L830-01AU	±10°		100		Φ 5	1
L830-02AU	±7°		100		Φ 5	2
L830-03AU	±10°		110		Φ 5	3
L830-04AU	±20°		45		Φ 5	4
L830-05AU	±40°		12		Φ 5	5
L830-06AU	±7°		130		Φ 5	6
L830-09AU	±25°(Long) ±15°(Short)		60		Φ 5 Oval	7
L830-46AU					Φ 5	8
L830-41AU	±16°		75		Φ 4	9
L830-42AU	±23°		40		Φ 4	10
L830-31AU					Φ 3	11
L830-33AU	±18°		45		Φ 3	12
L830-34AU					Φ 3	13
L830-36AU	±33°		20		Φ 3	14

Total Radiant Power is measured by Photodyne #500  
 Brightness is measured by Tektronix J-16

**Outer Dimension of LED Lamp**

<p><b>Figure-1 Φ 5Mold (Type01)</b></p> <p>cup position 4.7 1.5max</p> <p><math>\phi 5.8 \pm 0.2</math> <math>\phi 5 \pm 0.2</math></p> <p>9<math>\pm 0.2</math> 21 min. 1 typ.</p> <p>Cathode</p> <p>Anode 2-0.5sq<math>\pm 0.1</math></p> <p>1.0<math>\pm 0.2</math></p>	<p><b>Figure-2 Φ 5Mold (Type02)</b></p> <p>cup position 5.32 1.5max</p> <p><math>\phi 5.8 \pm 0.2</math> <math>\phi 5.2 \pm 0.2</math></p> <p>8.5<math>\pm 0.2</math> 21 min. 1 typ.</p> <p>Cathode</p> <p>Anode 2-0.5sq<math>\pm 0.1</math></p> <p>1.0<math>\pm 0.2</math></p>
<p><b>Figure-3 Φ 5Mold (Type03)</b></p> <p>cup position 4.55 1.5max</p> <p><math>\phi 5.8 \pm 0.2</math> <math>\phi 5 \pm 0.2</math></p> <p>8.25<math>\pm 0.2</math> 21 min. 1 typ.</p> <p>Cathode</p> <p>Anode 2-0.5sq<math>\pm 0.1</math></p> <p>1.0<math>\pm 0.2</math></p>	<p><b>Figure-4 Φ 5Mold (Type04)</b></p> <p>cup position 3.55 1.5max</p> <p><math>\phi 5.8 \pm 0.2</math> <math>\phi 5 \pm 0.2</math></p> <p>7.7<math>\pm 0.2</math> 21 min. 1 typ.</p> <p>Cathode</p> <p>Anode 2-0.5sq<math>\pm 0.1</math></p> <p>1.0<math>\pm 0.2</math></p>
<p><b>Figure-5 Φ 5Mold (Type05)</b></p> <p>cup position 0.55 1.5max</p> <p><math>\phi 5.4 \pm 0.2</math> <math>\phi 4.8 \pm 0.2</math></p> <p>21 min. 1 typ.</p> <p>Cathode</p> <p>Anode 2-0.5sq<math>\pm 0.1</math></p> <p>1.0<math>\pm 0.2</math></p>	<p><b>Figure-6 Φ 5Mold (Type06)</b></p> <p>cup position 5.6 1.5max</p> <p><math>\phi 5.5 \pm 0.2</math></p> <p>8.7<math>\pm 0.2</math> 21 min. 1 typ.</p> <p>Cathode</p> <p>Anode 2-0.5sq<math>\pm 0.1</math></p>
<p><b>Figure-7 Φ 5Mold (Type09)</b></p> <p>cup position 4.1 1.5max</p> <p><math>\phi 4.7 \pm 0.2</math> <math>\phi 5.5 \pm 0.2</math></p> <p>7.7<math>\pm 0.2</math> 21 min. 1 typ.</p> <p>Cathode</p> <p>Anode 2-0.5sq<math>\pm 0.1</math></p>	<p><b>Figure-8 Φ 5Mold (Type46)</b></p> <p>1.5max</p> <p><math>\phi 5.8 \pm 0.2</math> <math>\phi 4.8 \pm 0.2</math></p> <p>4.4<math>\pm 0.2</math> 21 min. 1 typ.</p> <p>Cathode</p> <p>Anode 2-0.5sq<math>\pm 0.1</math></p> <p>0.6</p>
<p><b>Figure-9 Φ 4Mold (Type41)</b></p> <p>cup position 3.05 1max</p> <p><math>\phi 4.7 \pm 0.2</math> <math>\phi 3.9 \pm 0.2</math></p> <p>6.45<math>\pm 0.2</math> 21 min. 1 typ.</p> <p>Cathode</p> <p>Anode 2-0.5sq<math>\pm 0.1</math></p> <p>1.5<math>\pm 0.2</math></p>	<p><b>Figure-10 Φ 4Mold (Type42)</b></p> <p>cup position 3.05 1max</p> <p><math>\phi 4.7 \pm 0.2</math> <math>\phi 3.9 \pm 0.2</math></p> <p>6.45<math>\pm 0.2</math> 21 min. 1 typ.</p> <p>Cathode</p> <p>Anode 2-0.5sq<math>\pm 0.1</math></p> <p>1.5<math>\pm 0.2</math></p>

**Outer Dimension of LED Lamp**

<p><b>Figure-11 <math>\Phi</math>3Mold (Type31)</b> cup position</p> <p>0.37 1max 3.5±0.2 21 min. Cathode 1 typ. Anode 2-0.5sq±0.1 1.5 typ. <math>\phi</math>3.6±0.2 <math>\phi</math>3±0.2</p>	<p><b>Figure-12 <math>\Phi</math>3Mold (Type33)</b> cup position</p> <p>2.65 1max 5.3 21 min. Cathode 1 typ. Anode 2-0.5sq±0.1 0.8 typ. <math>\phi</math>3.8±0.2 <math>\phi</math>3±0.2</p>
<p><b>Figure-13 <math>\Phi</math>3Mold (Type34)</b> cup position</p> <p>3.25 1max 5.3±0.2 21 min. Cathode 1 typ. Anode 2-0.5sq±0.1 1.5 typ. <math>\phi</math>3.8±0.2 <math>\phi</math>3±0.2</p>	<p><b>Figure-14 <math>\Phi</math>3Mold (Type36)</b> cup position</p> <p>2.1 1max 5.3±0.2 21 min. Cathode 1 typ. Anode 2-0.5sq±0.1 2±0.4 <math>\phi</math>4±0.2 <math>\phi</math>3±0.2</p>
<p><b>Figure-15</b></p>	<p><b>Figure-16</b></p>
<p><b>Figure-17</b></p>	<p><b>Figure-18</b></p>
<p><b>Figure-19</b></p>	<p><b>Figure-20</b></p>

The Viewing half angle

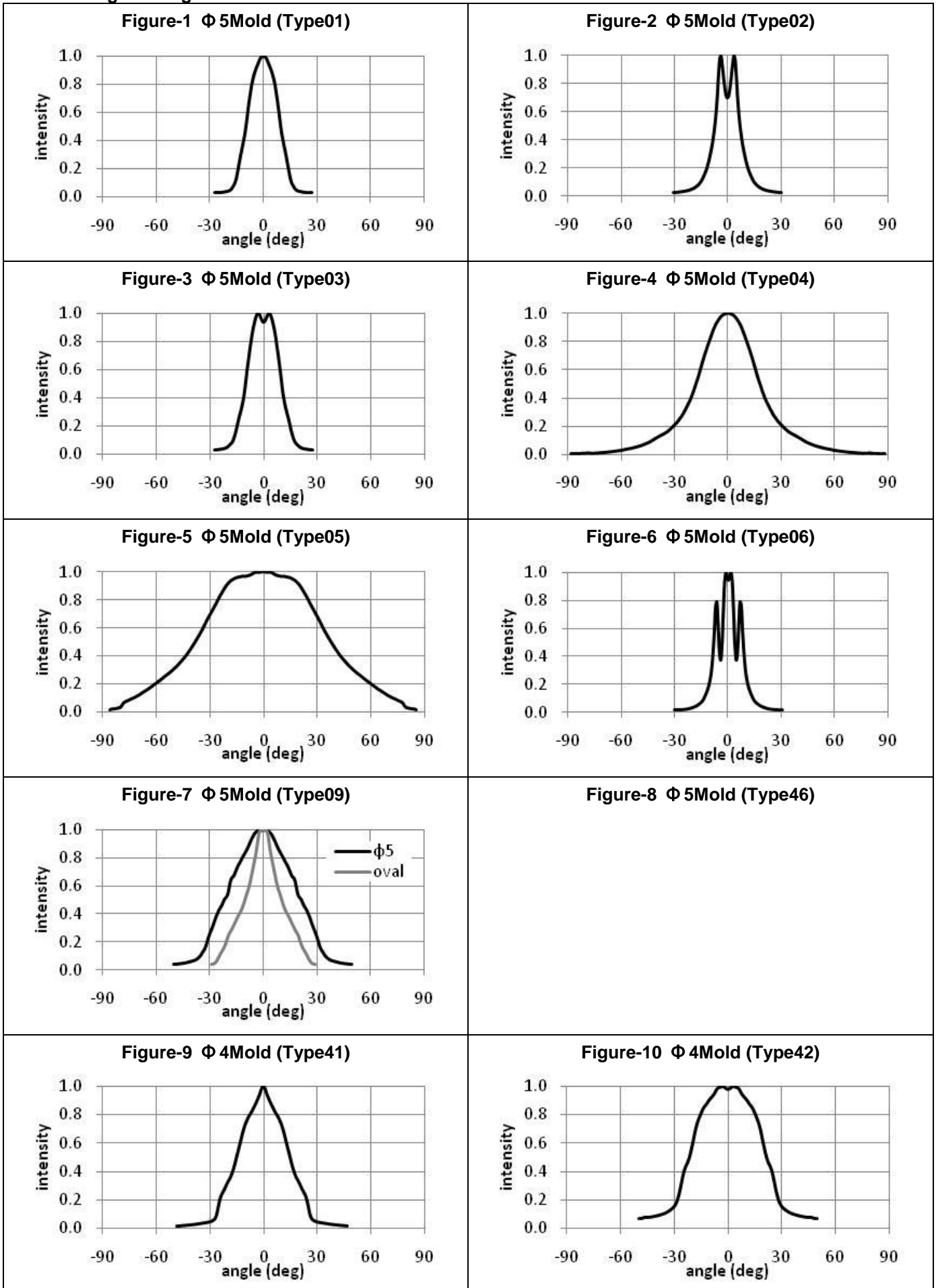

The Viewing half angle

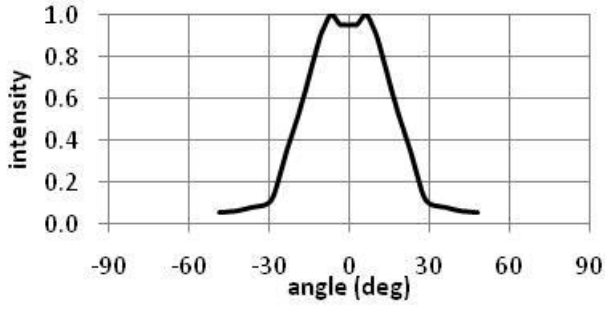
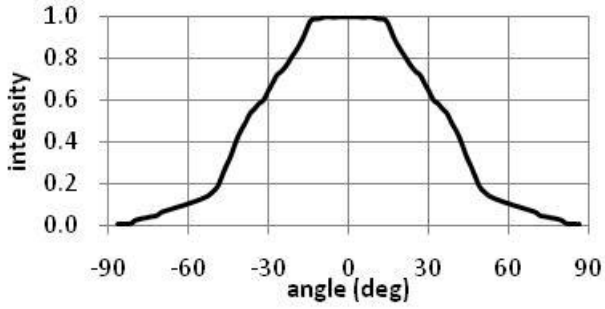
<p><b>Figure-11 <math>\Phi</math> 3Mold (Type31)</b></p>	<p><b>Figure-12 <math>\Phi</math> 3Mold (Type33)</b></p> 
<p><b>Figure-13 <math>\Phi</math> 3Mold (Type34)</b></p>	<p><b>Figure-14 <math>\Phi</math> 3Mold (Type36)</b></p> 
<p><b>Figure-15</b></p>	<p><b>Figure-16</b></p>
<p><b>Figure-17</b></p>	<p><b>Figure-18</b></p>
<p><b>Figure-19</b></p>	<p><b>Figure-20</b></p>

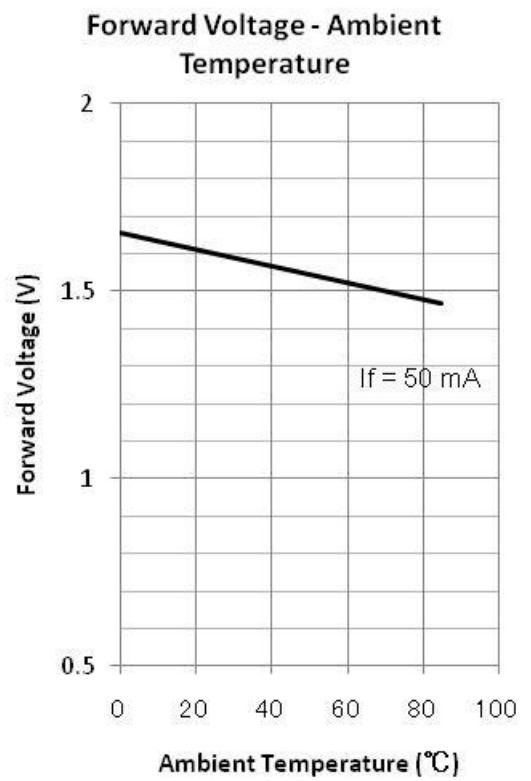
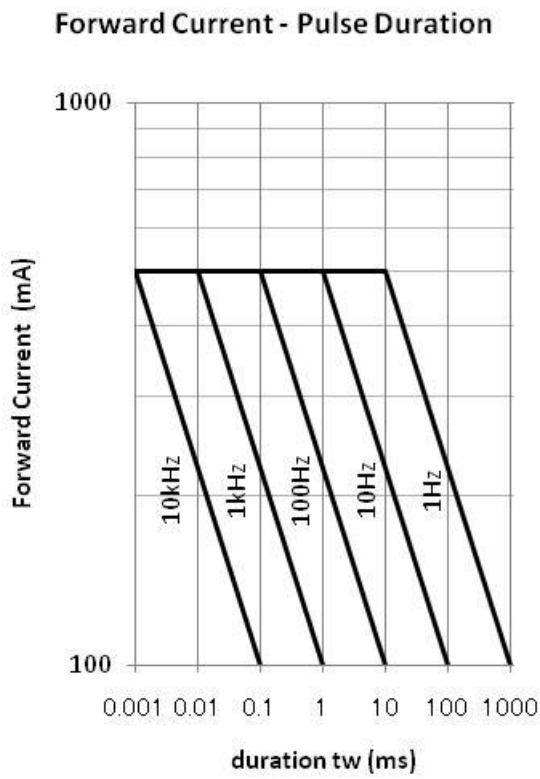
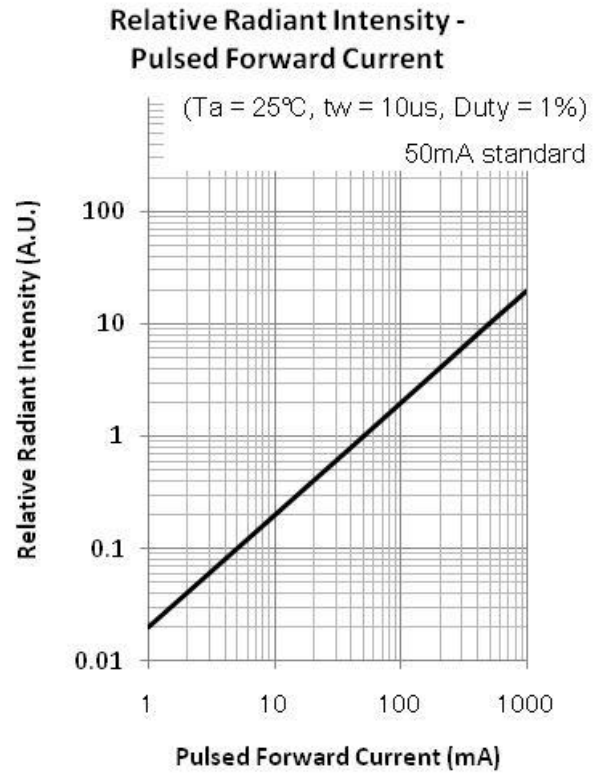
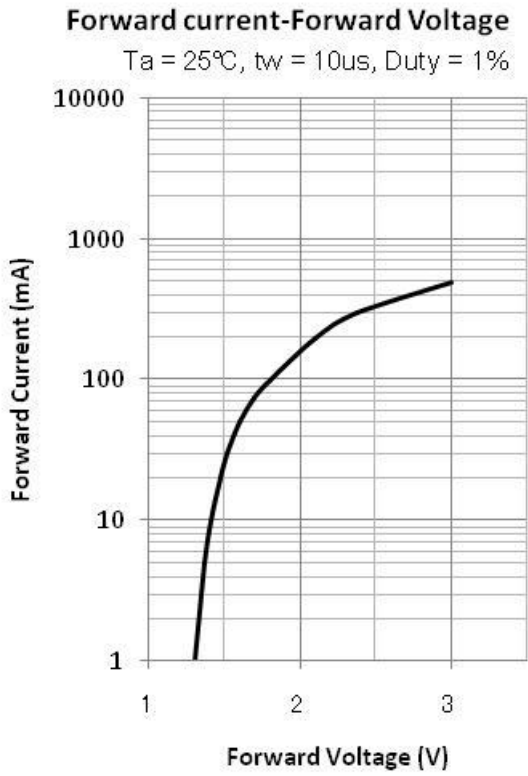

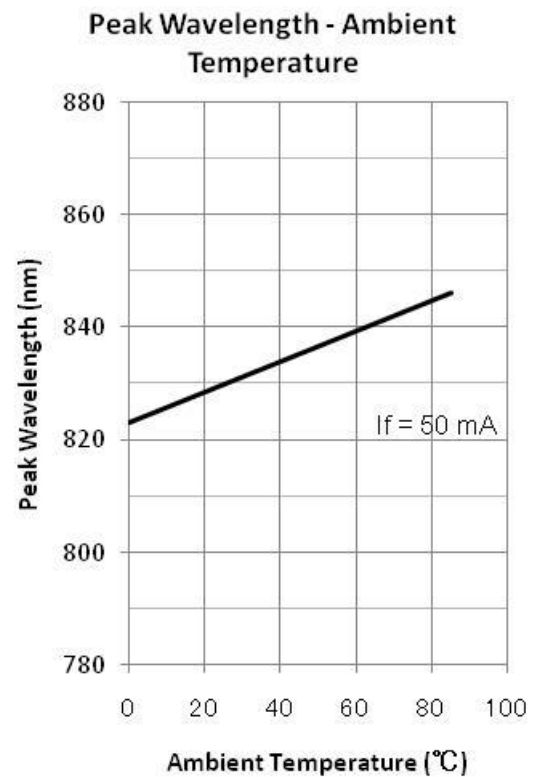
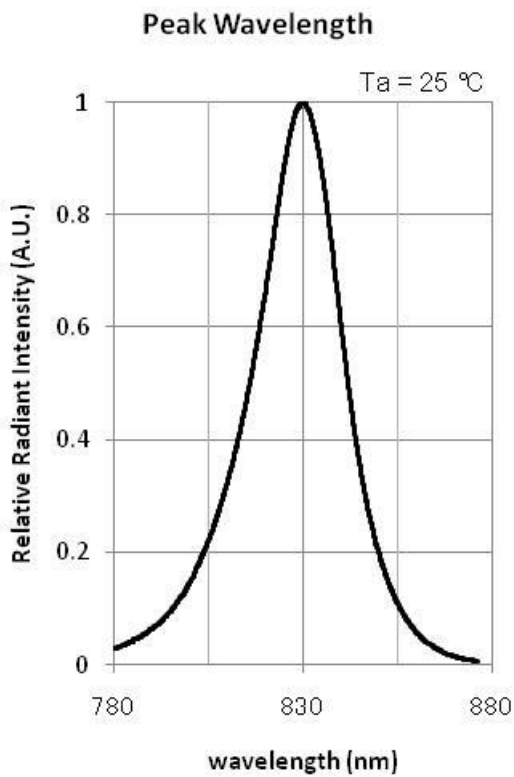
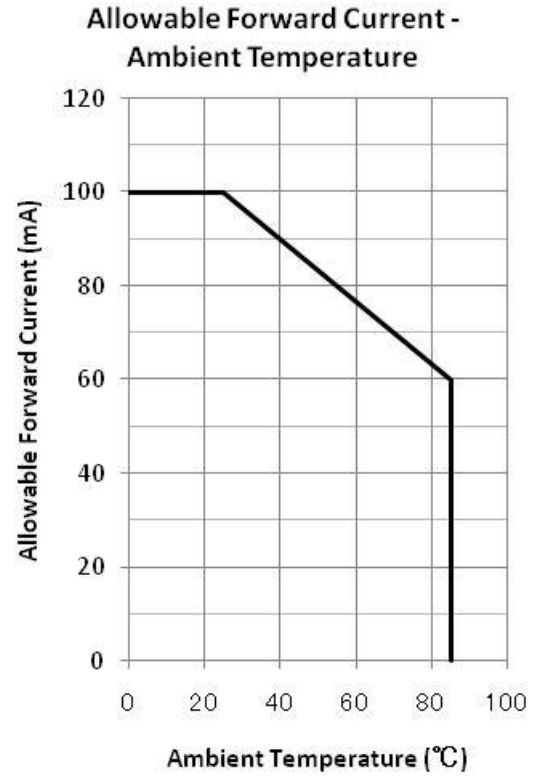
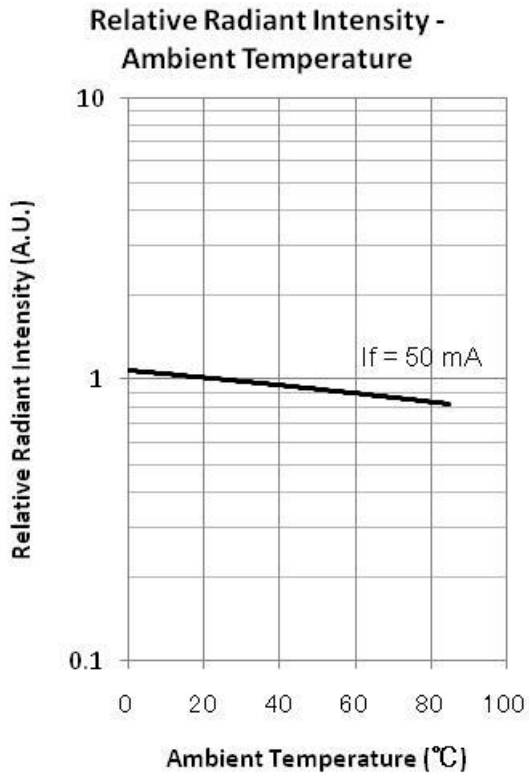

**Recommended Land Layout (unit: mm)**

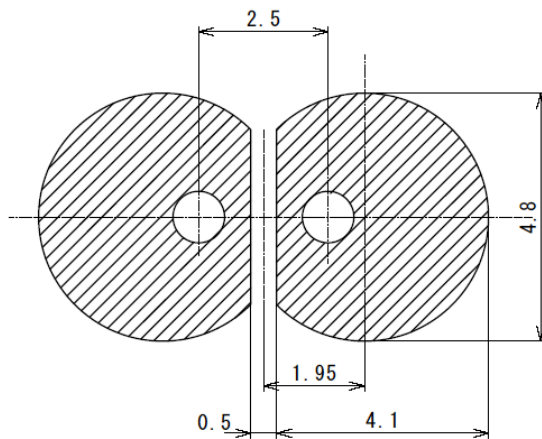

**Soldering Conditions**

