

L810N-66-16100 Epoxy Lens type Infrared Illuminator

L810N-66-16100 is a wide viewing and extremely high output power illuminator assembled with a total of 16pcs of 1mm square chips, mounted on a metal stem TO-66 with AlN ceramics and covered with epoxy resin. These devices are designed for high current operation with proper heat sinking to improve thermal conductive efficiency.

◆ Specifications

- 1) Product name IR illuminator
- 2) Spec. No. L810N-66-16100
- 3) Chip
 - (1) Chip Material AlGaAs
 - (2) Peak Wavelength 810m
 - (3) Chip Dimension 1mm*1mm
 - (4) Chip Number 16pcs
- 4) Package
 - (1) Stem TO-66 stem Cu made
 - (2) Insulator AlN ceramics
 - (3) Lens Clear Epoxy lens

◆ Outer dimension (Unit: mm)

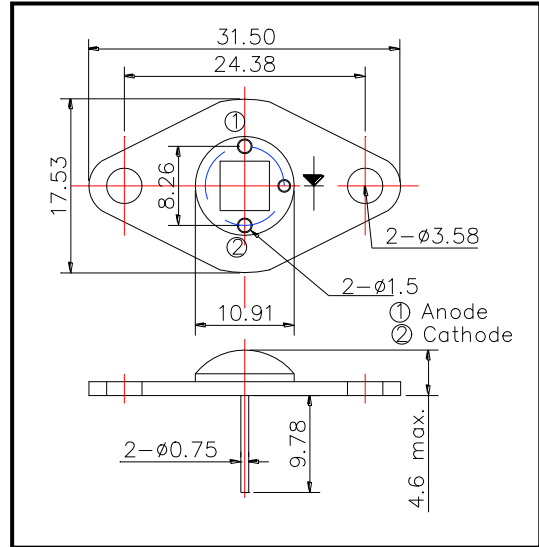

◆ Absolute Maximum Ratings

Item	Symbol	Maximum Rated Value	Unit	Ambient Temp.
Power Dissipation	P _D	16	W	T _a =25°C
Forward Current	I _F	2000	mA	T _a =25°C
Pulse Forward Current	I _{FP}	8	A	T _a =25°C
Reverse Voltage	V _R	50	V	T _a =25°C
Junction Temperature	T _J	100	°C	
Thermal Resistance	R _{thjp}	5	K/W	
Operating Temperature	T _{OPR}	-30 ~ +80	°C	
Storage Temperature	T _{STG}	-30 ~ +110	°C	
Soldering Temperature	T _{SOL}	265	°C	

‡Pulse Forward Current condition: Duty=1% and Pulse Width=10us.

‡Soldering condition: Soldering condition must be completed within 3 seconds at 265°C

‡Thermal resistance: junction – metal block.

◆ Electro-Optical Characteristics

Item	Symbol	Condition	Minimum	Typical	Maximum	Unit
Radiated Power	P _O	I _F =1200mA		1340		mW
		I _F =2A, t _p =1ms		2200		
Radiant Intensity	I _E	I _F =1200mA		530		mW/sr
		I _F =2A, t _p =1ms		880		
Forward Voltage	V _F	I _F =1200mA		6.4		V
		I _F =2A, t _p =1ms		6.9		
Peak Wavelength	λ _P	I _F =600mA		810		nm
Half Width	Δλ	I _F =600mA		35		nm
Viewing Half Angle	θ _{1/2}	I _F =600mA		±60		deg.
Rise Time	t _r	I _F =600mA		100		ns
Fall Time	t _f	I _F =600mA		100		ns

‡Heat sink is required by 2K/W.