

## L660/890-40D00 multi-wavelength LED

L660/890-40D00 consists of an AlGaAs'(660, 890nm), LED mounted on TO-18 stem with a glass ball lens.

On forward bias it emits a spectral band of radiation, which peaks at 660nm and 890nm without sub-peak.

### ◆ Outer dimension(Unit: mm)

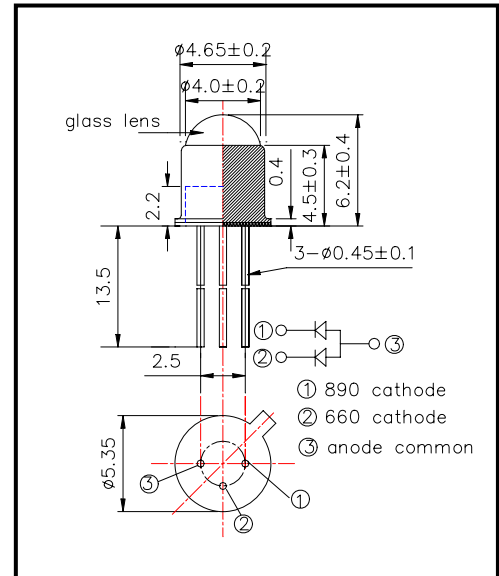

### ◆ Specifications

- |                     |                            |
|---------------------|----------------------------|
| 1) Product Name     | Multi-wavelength LED Lamp  |
| 2) Type No.         | L660/890-40D00             |
| 3) Chip             |                            |
| (1) Chip material   | AlGaAs,                    |
| (2) Chip dimension  | 350um(660nm), 400um(890nm) |
| (3) Peak wavelength | 660nm, 890nm               |
| 4) Package          |                            |
| (1) Stem            | TO-18 3pins type           |
| (2) Lens            | Epoxy potting              |

### ◆ Absolute Maximum Ratings [Ta=25°C]

Item	Symbol	Maximum Rated Value		Unit
		660	890	
Power Dissipation	PD	120	150	mW
Forward Current	IF	50	100	mA
Pulse Forward Current	IF	200	500	mA
Reverse Voltage	VR	5		V
Operating Temperature	TOPR	-20 ~ +80		°C
Storage Temperature	TSTG	-30 ~ +100		°C
Soldering Temperature	TSOL	240		°C

‡Soldering condition: Soldering condition must be completed within 3 seconds at 240°C and is allowed in the area apart 3mm from the bottom of the lamp.

### ◆ Electro-Optical Characteristics [Ta=25°C]

Symbol	Wavelength	Condition	Minimum	Typical	Maximum	Unit
VF	660	IF=20mA		1.9	2.2	V
	890			1.30	1.5	
IR	660/890	VR=5V			10	uA
PO	660	IF=20mA		1.3		mW
	890			2.0		
IE	660	IF=20mA		13.0		mW/sr
	890			15.0		
λP	660	IF=20mA	650	660	670	nm
	890		880	890	900	
Δλ	660	IF=20mA		20		nm
	890			65		

‡Total Radiated Power is measured by Photodyne #500

‡Radiant Intensity is measured by Tektronix J-6512.

# Marubeni

---

**Marubeni America Corporation**

3945 Freedom Circle, Suite 1000, Santa Clara, CA 95054

408-330-0650 (Ext. 323), 408-330-0655 (Fax), [sales@tech-led.com](mailto:sales@tech-led.com)