

L660/850-33 Bi-Color LED for medical analysis

Bi-color LED of L660/850-33 consists of AlGaAs mounted on a lead frame with a clear epoxy lens. On forward bias it emits 660nm and 850nm as peak wavelength with anode common.

◆ Features

- 1) Precious wavelength
- 2) High Reliability
- 3) Anode Common

◆ Specifications

- 1) Product Name Bi-color LED
- 2) Type No. L660/850-33
- 3) Chip
- (1) Chip Material AlGaAs (sub-peak free)
- (2) Peak Wavelength 660nm and 850nm typ.
- 4) Package
- (1) Type Φ 3mm clear molding
- (2) Resin Material Epoxy Resin
- (3) Lead Frame Soldered(Lead Free)

◆ Outer dimension (Unit: mm)

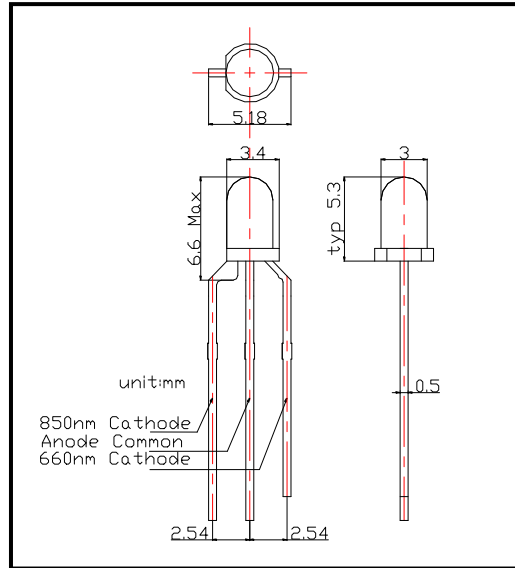

◆ Absolute Maximum Ratings

Item	Symbol	Maximum Rated Value		Unit	Ambient Temperature
		660nm	850nm		
Power Dissipation	PD	75	160	mW	Ta=25°C
Forward Current	IF	30	50	mA	Ta=25°C
Reverse Voltage	IR	10		V	Ta=25°C
Operating Temperature	TOPR	-40 ~ +85		°C	
Storage Temperature	TSTG	-40 ~ +100		°C	
Soldering Temperature	TSOL	265		°C	

‡Soldering condition: Soldering condition must be completed within 3 seconds at 265°C

◆ Electro-Optical Characteristics [Ta=25°C]

Item	Symbol	Condition	Minimum		Typical		Maximum		Unit
			660nm	850nm	660nm	850nm	660nm	850nm	
Forward Voltage	VF	IF=20mA			1.90	1.40	2.20	1.60	V
Reverse Current	IR	VR=5V					10		uA
Total Radiated Power	PO	IF=20mA	2.5	4.5	3.5	7.0			mW
Peak Wavelength	λ_P	IF=20mA	650	840	660	850	670	860	nm
Half Width	$\Delta\lambda$	IF=20mA			20	35			nm
Viewing Half Angle	$\theta_{1/2}$	IF=20mA			± 15				deg.

‡Total Radiated Power is measured by Photodyne #500

‡Radiant Intensity is measured by Tektronix J-6512