

L660-66-60 epoxy lens type RED color illuminator

L660-66-60 is a wide viewing and extremely high output power illuminator assembled with a total of 60 high efficiency AlGaAs diode chips, mounted on a metal stem TO-66 with AlN ceramics and covered with double coated clear silicone and epoxy resin. These devices are designed for high current operation with proper heat sinking to improve thermal conductive efficiency.

◆ Features

- 1) High reliability
- 2) Compact (TO-66) package
- 3) High output power at 660nm

◆ Applications

- 1) For high intensity lighting source

◆ Specifications

- 1) Product name Red color illuminator
- 2) Spec. No. L660-66-60
- 3) Chip
- (1) Material AlGaAs
- (2) Peak wavelength 660nm
- 4) Package
- (1) Stem TO-66 stem with AlN
- (2) Lens Clear epoxy lens

◆ Outer dimension (Unit: mm)

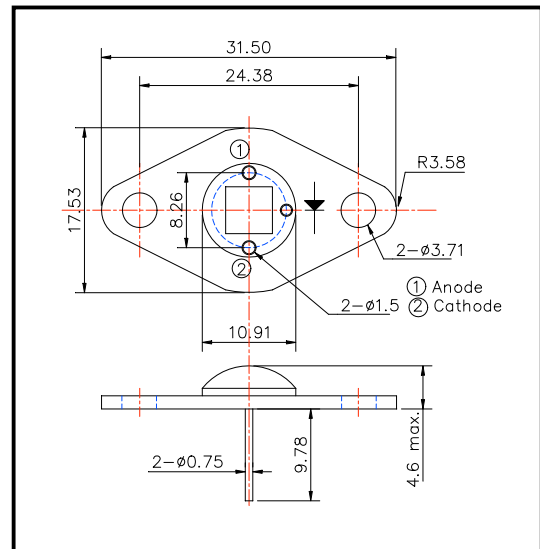

◆ Absolute Maximum Ratings

Item	Symbol	Maximum Rated Value	Unit	Ambient Temp.
Power Dissipation	P _D	4.5	W	T _a =25°C
Forward Current	I _F	400	mA	T _a =25°C
Pulse Forward Current	I _{FP}	600	mA	T _a =25°C
Reverse Voltage	V _R	50	V	T _a =25°C
Operating Temperature	T _{OPR}	-30 ~ +80	°C	
Storage Temperature	T _{STG}	-30 ~ +110	°C	
Soldering Temperature	T _{SOL}	240	°C	

‡Pulse Forward Current condition: Duty=1% and Pulse Width=1us.

‡Soldering condition: Soldering condition must be completed within 3 seconds at 260°C

◆ Electro-Optical Characteristics

Item	Symbol	Condition	Minimum	Typical	Maximum	Unit
Forward Voltage	V _F	I _F =240mA		10.0		V
Brightness	I _v	I _F =240mA		-		mcd
Total Radiated Power	P _O	I _F =240mA		100		mW
Radiant Intensity	I _E	I _F =240mA		-		mW/sr
Reverse Current	V _R	I _R =10uA	50			V
Peak Wavelength	λ _P	I _F =240mA		650		nm
Half Width	Δλ	I _F =240mA		20		nm
Viewing Half Angle	θ _{1/2}	I _F =240mA		±60		deg.

‡Total Radiated Power is measured by S3584-08

‡LED is required to keep less than 60°C.