

## L570-66-60 epoxy lens type Yellow color illuminator

L570-66-60 is a wide viewing and extremely high output power illuminator assembled with a total of 60 high efficiency InGaAlP diode chips, mounted on a metal stem TO-66 with AlN ceramics and covered with double coated clear silicone and epoxy resin. These devices are designed for high current operation with proper heat sinking to improve thermal conductive efficiency.

### ◆ Features

- 1) High reliability
- 2) Compact (TO-66) package
- 3) High output power at 570nm

### ◆ Applications

- 1) For high intensity lighting source

### ◆ Specifications

- 1) Product name Yellow color illuminator
- 2) Spec. No. L570-66-60
- 3) Chip
  - (1) Material InGaAlP
  - (2) Peak wavelength 570nm
- 4) Package
  - (1) Stem TO-66 stem with AlN
  - (2) Lens Clear epoxy lens

### ◆ Outer dimension (Unit: mm)

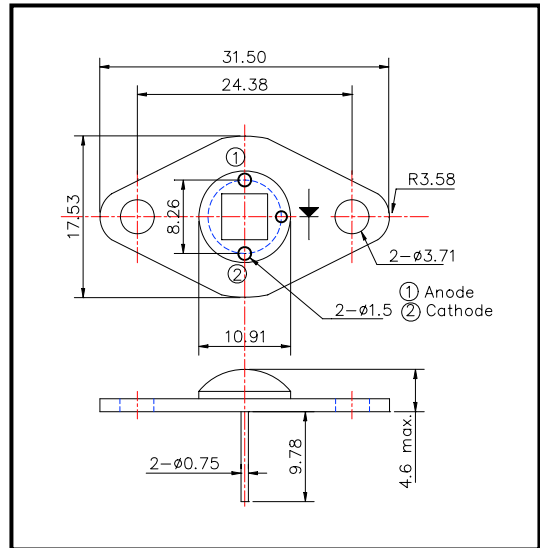

Item	Symbol	Maximum Rated Value	Unit	Ambient Temp.
Power Dissipation	P <sub>D</sub>	4.5	W	T <sub>a</sub> =25°C
Forward Current	I <sub>F</sub>	400	mA	T <sub>a</sub> =25°C
Pulse Forward Current	I <sub>FP</sub>	600	mA	T <sub>a</sub> =25°C
Reverse Voltage	V <sub>R</sub>	50	V	T <sub>a</sub> =25°C
Operating Temperature	T <sub>OPR</sub>	-30 ~ +80	°C	
Storage Temperature	T <sub>STG</sub>	-30 ~ +110	°C	
Soldering Temperature	T <sub>SOL</sub>	240	°C	

‡Pulse Forward Current condition: Duty=1% and Pulse Width=1us.

‡Soldering condition: Soldering condition must be completed within 3 seconds at 260°C

### ◆ Electro-Optical Characteristics

Item	Symbol	Condition	Minimum	Typical	Maximum	Unit
Forward Voltage	V <sub>F</sub>	I <sub>F</sub> =240mA		11.0		V
Brightness	I <sub>v</sub>	I <sub>F</sub> =240mA		7000		mcd
Total Radiated Power	P <sub>O</sub>	I <sub>F</sub> =240mA		36		mW
Reverse Current	V <sub>R</sub>	I <sub>R</sub> =10uA	50			V
Peak Wavelength	λ <sub>P</sub>	I <sub>F</sub> =240mA	560	570	580	nm
Half Width	Δλ	I <sub>F</sub> =240mA		15		nm
Viewing Half Angle	θ <sub>1/2</sub>	I <sub>F</sub> =240mA		±60		deg.

‡Heat sink is required thermal resistance <8K/W