

L470/660-04A Bi-Color LED for medical uses

Bi-color LED of L470/660-04A consists of an InGaN LED and an AlGaAs LEDs mounted on a lead frame with a clear epoxy lens.

On forward bias it emits a band of visible light, which peaks 470nm and 660nm at anode common.

◆ Features

- 1) High Reliability
- 2) High Power
- 3) Anode Common

◆ Specifications

- 1) Product Name Bi-color LED
- 2) Type No. L470/660-04A
- 3) Chip
 - (1) Chip Material InGaN and AlGaAs
 - (2) Peak Wavelength 470nm and 660nm typ.
- 4) Package
 - (1) Type Φ 5mm clear molding
 - (2) Resin Material Epoxy Resin
 - (3) Lead Frame Soldered

◆ Outer dimension (Unit: mm)

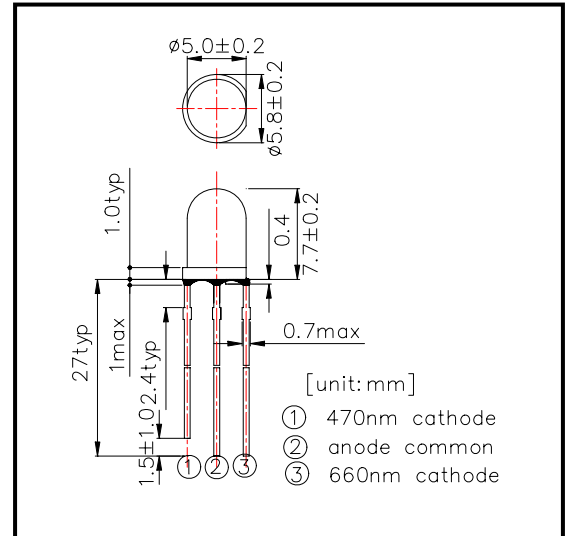

◆ Absolute Maximum Ratings

Item	Symbol	Maximum Rated Value		Unit	Ambient Temperature
		470nm	660nm		
Power Dissipation	PD	120	75	mW	Ta=25°C
Forward Current	IF	30	30	mA	Ta=25°C
Reverse Voltage	IR	5		V	Ta=25°C
Operating Temperature	TOPR	-30 ~ +85		°C	
Storage Temperature	TSTG	-30 ~ +100		°C	
Soldering Temperature	TSOL	260		°C	

‡Soldering condition: Soldering condition must be completed within 3 seconds at 260°C

◆ Electro-Optical Characteristics [Ta=25°C]

Item	Symbol	Condition	Minimum		Typical		Maximum		Unit
			470nm	660nm	470nm	660nm	470nm	660nm	
Forward Voltage	VF	IF=20mA			3.60	1.90	4.30	2.20	V
Reverse Current	IR	VR=5V							uA
Total Radiated Power	PO	IF=20mA	2.5	2.5	5.0	4.0			mW
Radiant Intensity	IE	IF=20mA	4.5	4.0	7.5	7.0			mW/sr
Peak Wavelength	λ P	IF=20mA	460	645	470	655	480	665	nm
Half Width	$\Delta\lambda$	IF=20mA			25	20			nm
Viewing Half Angle	θ 1/2	IF=20mA			±20				deg.

‡Total Radiated Power is measured by Photodyne #500

‡Radiant Intensity is measured by Tektronix J-6512