

## L470-66-60 epoxy lens type BLUE color illuminator

L470-66-60 is a wide viewing and extremely high output power illuminator assembled with a total of 60 high efficiency InGaN diode chips, mounted on a metal stem TO-66 with AlN ceramics and covered with double coated clear silicone and epoxy resin. These devices are designed for high current operation with proper heat sinking to improve thermal conductive efficiency.

### ◆ Features

- 1) High reliability
- 2) Compact (TO-66) package
- 3) High output power at 470nm

### ◆ Applications

- 1) For high intensity lighting source

### ◆ Specifications

- 1) Product name Blue color illuminator
- 2) Spec. No. L470-66-60
- 3) Chip InGaN
- (1) Material InGaN
- (2) Peak wavelength 470m
- 4) Package TO-66 stem with AlN
- (1) Stem TO-66 stem with AlN
- (2) Lens Clear silicone and epoxy lens

### ◆ Outer dimension (Unit: mm)

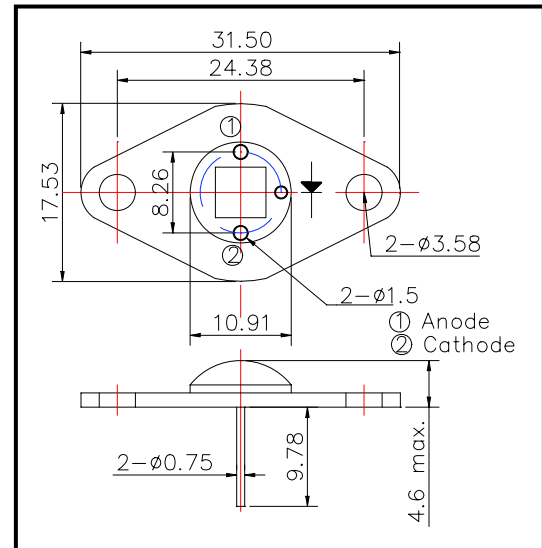

### ◆ Absolute Maximum Ratings

Item	Symbol	Maximum Rated Value	Unit	Ambient Temp.
Power Dissipation	PD	7.5	W	Ta=25°C
Forward Current	IF	400	mA	Ta=25°C
Pulse Forward Current	IFP	500	mA	Ta=25°C
Reverse Voltage	VR	50	V	Ta=25°C
Operating Temperature	TOPR	-30 ~ +80	°C	
Storage Temperature	TSTG	-30 ~ +110	°C	
Soldering Temperature	TSOL	240	°C	

‡Pulse Forward Current condition: Duty=1% and Pulse Width=1us.

‡Soldering condition: Soldering condition must be completed within 3 seconds at 260°C

### ◆ Electro-Optical Characteristics

Item	Symbol	Condition	Minimum	Typical	Maximum	Unit
Forward Voltage	VF	IF=240mA		18.5		V
Brightness	IV	IF=240mA		4500		mcd
Total Radiated Power	PO	IF=240mA		120		mW
Radiant Intensity	IE	IF=240mA		33		mW/sr
Reverse Current	VR	IR=10uA	50			V
Peak Wavelength	λP	IF=240mA	460	470	480	nm
Half Width	Δλ	IF=240mA		20		nm
Viewing Half Angle	θ 1/2	IF=240mA		±60		deg.

‡Heat sink is required thermal resistance <8K/W