

# L415R-\_\_ \_\_ UV LED Lamp with UV resistant resin

This series of L415R-\_\_ \_\_ is an InGaN LED mounted on a lead frame with a clear silicone lens. On forward bias, it emits a band of visible light peaks 415nm.

### Specifications

- |                    |                      |
|--------------------|----------------------|
| 1. Chip material   | InGaN                |
| 2. Peak wavelength | 415nm typ.           |
| 3. Resin Material  | Clear Silicone Resin |
| 4. Solder          | Lead free            |



### Absolute Maximum Ratings

Item	Symbol	Maximum Rated Value	Unit	Ambient Temperature
Power Dissipation	$P_D$	200	mW	$T_a=25^{\circ}\text{C}$
Forward Current	$I_F$	50	mA	$T_a=25^{\circ}\text{C}$
Reverse Voltage	$V_R$	5	V	$T_a=25^{\circ}\text{C}$
Operating Temperature	$T_{OPR}$	-30 ~ +85	$^{\circ}\text{C}$	$T_a=25^{\circ}\text{C}$
Storage Temperature	$T_{STG}$	-40 ~ +100	$^{\circ}\text{C}$	
Soldering Temperature	$T_{SOL}$	265	$^{\circ}\text{C}$	

### Electro-Optical Characteristics ( $T_a=25^{\circ}\text{C}$ )

Item	Symbol	Condition	Minimum	Typical	Maximum	Unit
Forward Voltage	$V_F$	$I_F=20\text{mA}$		3.4	4.0	V
Reverse Current	$I_R$	$V_R=5\text{V}$			10	$\mu\text{A}$
Radiated Power	$P_O$	$I_F=20\text{mA}$		15		mW
Peak Wavelength	$\lambda_P$	$I_F=20\text{mA}$	410	415	420	nm
Half Width	$\Delta\lambda$	$I_F=20\text{mA}$		15		nm

**Characteristics of Radiant Intensity (Ta=25°C)**

Type	Viewing Half Angle	Radiant Intensity I <sub>F</sub> =20mA Unit : mW/sr			Outer Dimension	Dimension Figure
		Minimum	Typical	Maximum		
L415R-01	±8°		60		Φ 5	1
L415R-02	±5°		60		Φ 5	2
L415R-03	±10°		40		Φ 5	3
L415R-04	±20°		12		Φ 5	4
L415R-05	±50°		4		Φ 5	5
L415R-06	±4°		90		Φ 5	6
L415R-09	±25°(Long) ±10°(Short)				Φ 5 Oval	7
L415R-46					Φ 5	8
L415R-41	±14°				Φ 4	9
L415R-42	±20°				Φ 4	10
L415R-31					Φ 3	11
L415R-33	±13°		18		Φ 3	12
L415R-34					Φ 3	13
L415R-36	±25°		9		Φ 3	14

Radiated Power is measured by S3584-08.

Radiant Intensity is measured by Ando Optical Multi Meter AQ2140 & AQ2741.

**Outer Dimension of LED Lamp**

<p><b>Figure-1 Φ 5Mold (Type01)</b></p> <p>cup position 4.7 1.5max</p> <p><math>\phi 5.8 \pm 0.2</math> <math>\phi 5 \pm 0.2</math></p> <p>9<math>\pm 0.2</math> 21 min. Cathode 1 typ.</p> <p>1.0<math>\pm 0.2</math> Anode 2-0.5sq<math>\pm 0.1</math></p>	<p><b>Figure-2 Φ 5Mold (Type02)</b></p> <p>cup position 5.32 1.5max</p> <p><math>\phi 5.8 \pm 0.2</math> <math>\phi 5.2 \pm 0.2</math></p> <p>8.5<math>\pm 0.2</math> 21 min. Cathode 1 typ.</p> <p>1.0<math>\pm 0.2</math> Anode 2-0.5sq<math>\pm 0.1</math></p>
<p><b>Figure-3 Φ 5Mold (Type03)</b></p> <p>cup position 4.55 1.5max</p> <p><math>\phi 5.8 \pm 0.2</math> <math>\phi 5 \pm 0.2</math></p> <p>8.25<math>\pm 0.2</math> 21 min. Cathode 1 typ.</p> <p>1.0<math>\pm 0.2</math> Anode 2-0.5sq<math>\pm 0.1</math></p>	<p><b>Figure-4 Φ 5Mold (Type04)</b></p> <p>cup position 3.55 1.5max</p> <p><math>\phi 5.8 \pm 0.2</math> <math>\phi 5 \pm 0.2</math></p> <p>7.7<math>\pm 0.2</math> 21 min. Cathode 1 typ.</p> <p>1.0<math>\pm 0.2</math> Anode 2-0.5sq<math>\pm 0.1</math></p>
<p><b>Figure-5 Φ 5Mold (Type05)</b></p> <p>cup position 0.55 1.5max</p> <p><math>\phi 5.4 \pm 0.2</math> <math>\phi 4.8 \pm 0.2</math></p> <p>20.25 21 min. Cathode 1 typ.</p> <p><math>\phi 4.45 \pm 0.2</math> 1.0<math>\pm 0.2</math> Anode 2-0.5sq<math>\pm 0.1</math></p>	<p><b>Figure-6 Φ 5Mold (Type06)</b></p> <p>cup position 5.6 1.5max</p> <p><math>\phi 5.5 \pm 0.2</math></p> <p>8.7<math>\pm 0.2</math> 21 min. Cathode 1 typ.</p> <p>Anode 2-0.5sq<math>\pm 0.1</math></p>
<p><b>Figure-7 Φ 5Mold (Type09)</b></p> <p>cup position 4.1 1.5max</p> <p>4.7<math>\pm 0.2</math> 7.7<math>\pm 0.2</math> 21 min. Cathode 1 typ.</p> <p>5.5<math>\pm 0.2</math> Anode 2-0.5sq<math>\pm 0.1</math></p>	<p><b>Figure-8 Φ 5Mold (Type46)</b></p> <p>1.5max</p> <p><math>\phi 5.8 \pm 0.2</math> <math>\phi 4.8 \pm 0.2</math></p> <p>4.4<math>\pm 0.2</math> 21 min. Cathode 1 typ.</p> <p>0.6 Anode 2-0.5sq<math>\pm 0.1</math></p>
<p><b>Figure-9 Φ 4Mold (Type41)</b></p> <p>cup position 3.05 1max</p> <p><math>\phi 4.7 \pm 0.2</math> <math>\phi 3.9 \pm 0.2</math></p> <p>6.45<math>\pm 0.2</math> 21 min. Cathode 1 typ.</p> <p>1.5<math>\pm 0.2</math> Anode 2-0.5sq<math>\pm 0.1</math></p>	<p><b>Figure-10 Φ 4Mold (Type42)</b></p> <p>cup position 3.05 1max</p> <p><math>\phi 4.7 \pm 0.2</math> <math>\phi 3.9 \pm 0.2</math></p> <p>6.45<math>\pm 0.2</math> 21 min. Cathode 1 typ.</p> <p>1.5<math>\pm 0.2</math> Anode 2-0.5sq<math>\pm 0.1</math></p>

**Outer Dimension of LED Lamp**

<p><b>Figure-11 <math>\Phi</math> 3Mold (Type31)</b> cup position</p> <p>0.37 1max <math>\phi</math> 3.6<math>\pm</math>0.2 <math>\phi</math> 3<math>\pm</math>0.2 3.5<math>\pm</math>0.2 21 min. Cathode 1 typ. Anode 2-0.5sq<math>\pm</math>0.1 1.5 typ.</p>	<p><b>Figure-12 <math>\Phi</math> 3Mold (Type33)</b> cup position</p> <p>2.65 1max <math>\phi</math> 3.8<math>\pm</math>0.2 <math>\phi</math> 3<math>\pm</math>0.2 5.3 21 min. Cathode 1 typ. Anode 2-0.5sq<math>\pm</math>0.1 0.8 typ.</p>
<p><b>Figure-13 <math>\Phi</math> 3Mold (Type34)</b> cup position</p> <p>3.25 1max <math>\phi</math> 3.8<math>\pm</math>0.2 <math>\phi</math> 3<math>\pm</math>0.2 5.3<math>\pm</math>0.2 21 min. Cathode 1 typ. Anode 2-0.5sq<math>\pm</math>0.1 1.5 typ.</p>	<p><b>Figure-14 <math>\Phi</math> 3Mold (Type36)</b> cup position</p> <p>2.1 1max <math>\phi</math> 4<math>\pm</math>0.2 <math>\phi</math> 3<math>\pm</math>0.2 5.3<math>\pm</math>0.2 21 min. Cathode 1 typ. Anode 2-0.5sq<math>\pm</math>0.1 2<math>\pm</math>0.4</p>
<p><b>Figure-15</b></p>	<p><b>Figure-16</b></p>
<p><b>Figure-17</b></p>	<p><b>Figure-18</b></p>
<p><b>Figure-19</b></p>	<p><b>Figure-20</b></p>

The Viewing half angle

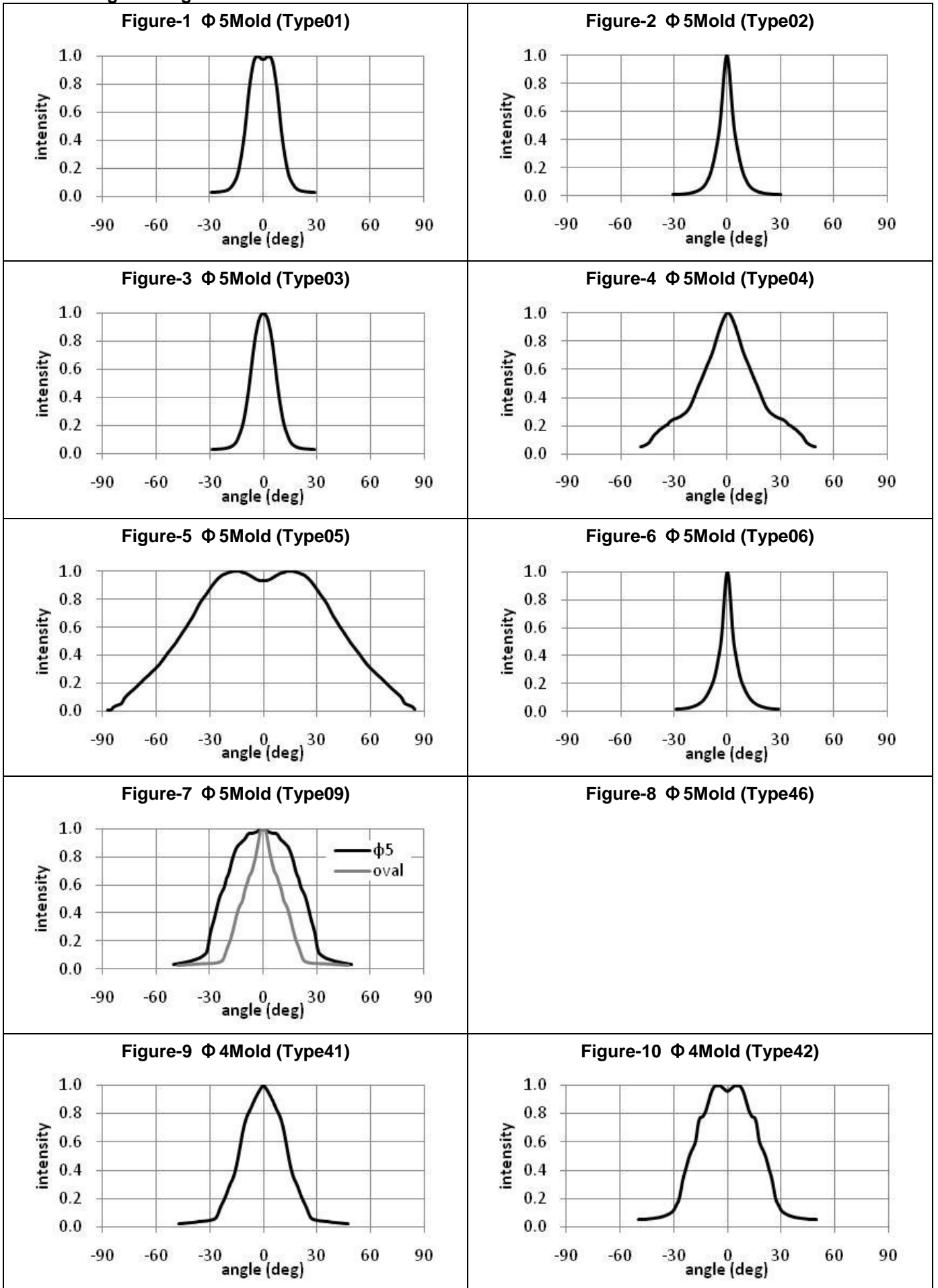

**The Viewing half angle**

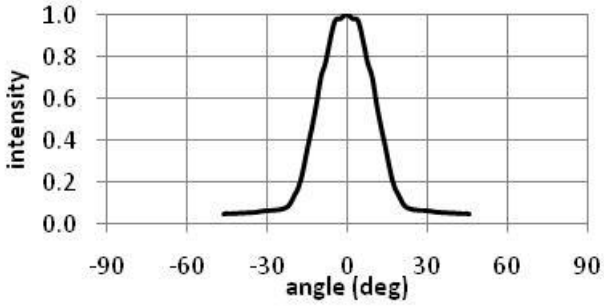
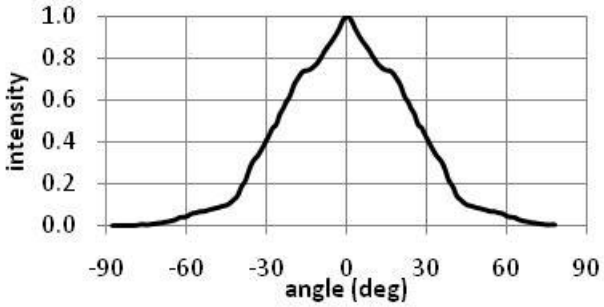
<p><b>Figure-11 <math>\Phi</math> 3Mold (Type31)</b></p>	<p><b>Figure-12 <math>\Phi</math> 3Mold (Type33)</b></p> 
<p><b>Figure-13 <math>\Phi</math> 3Mold (Type34)</b></p>	<p><b>Figure-14 <math>\Phi</math> 3Mold (Type36)</b></p> 
<p><b>Figure-15</b></p>	<p><b>Figure-16</b></p>
<p><b>Figure-17</b></p>	<p><b>Figure-18</b></p>
<p><b>Figure-19</b></p>	<p><b>Figure-20</b></p>

L415R –series

**Forward current-Forward Voltage**

$T_a = 25^\circ\text{C}$ ,  $t_w = 10\mu\text{s}$ , Duty = 1%

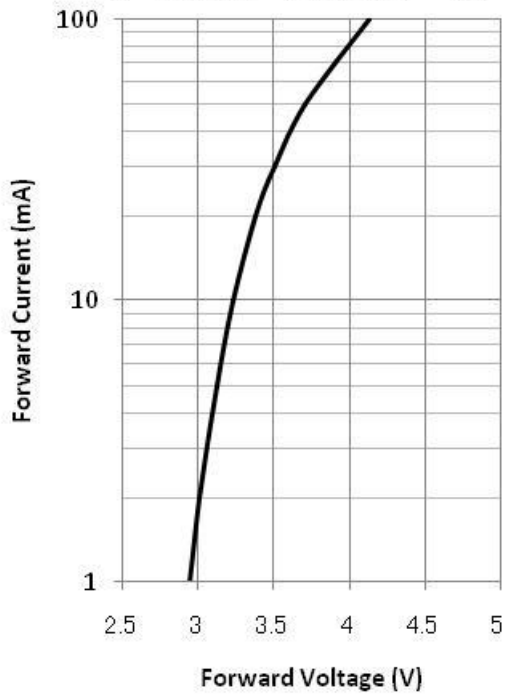

**Relative Radiant Intensity - Pulsed Forward Current**

( $T_a = 25^\circ\text{C}$ ,  $t_w = 10\mu\text{s}$ , Duty = 1%)

20mA standard

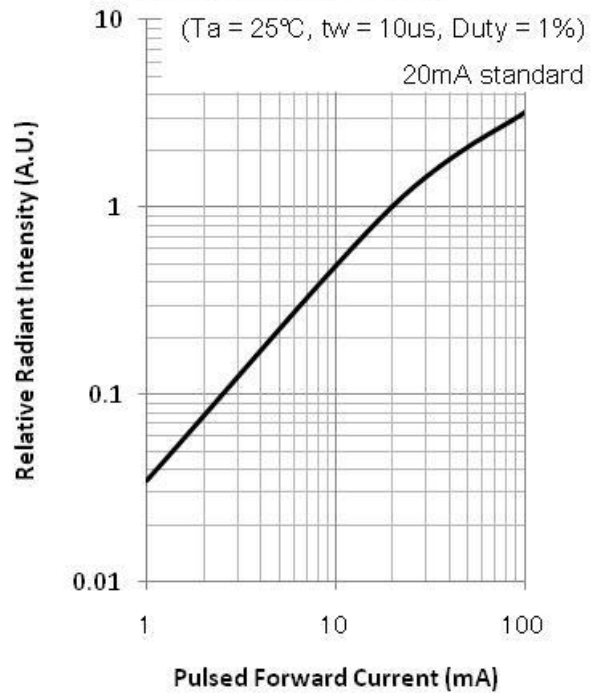

**Forward Voltage - Ambient Temperature**

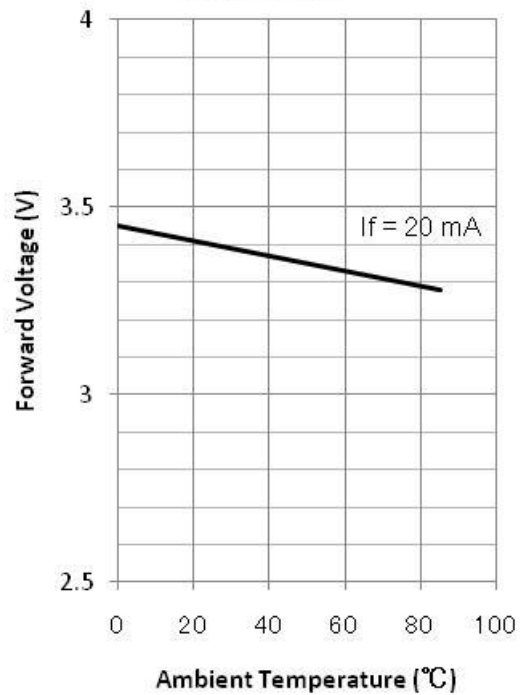

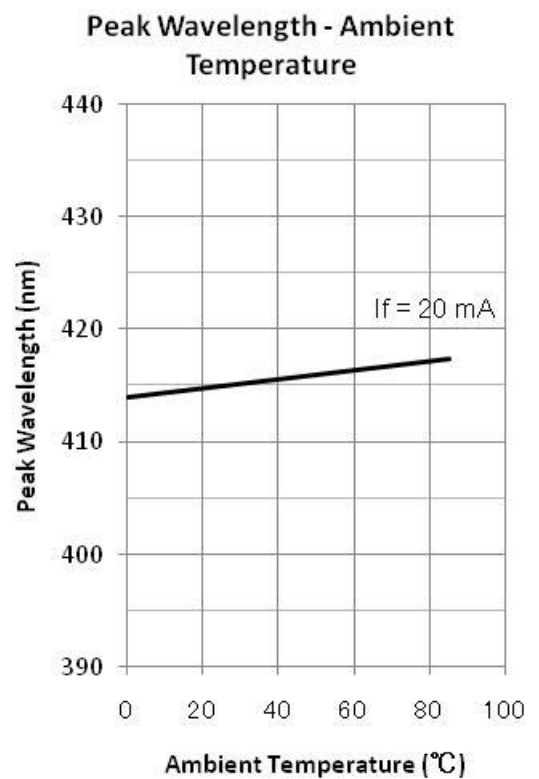
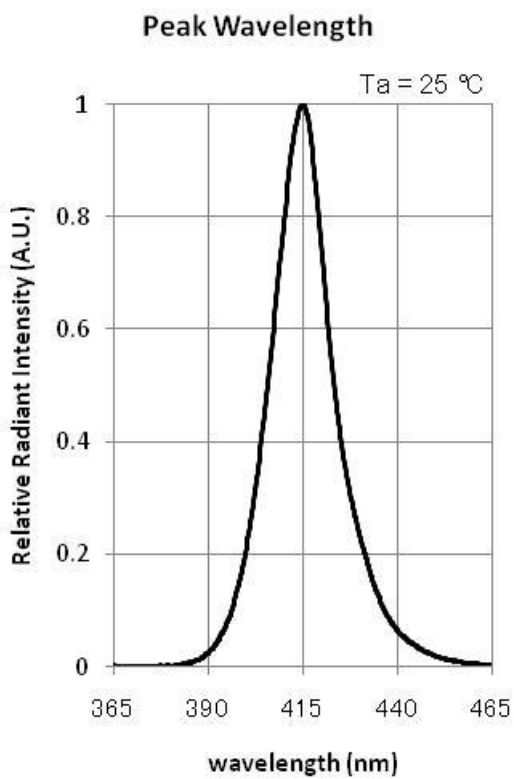
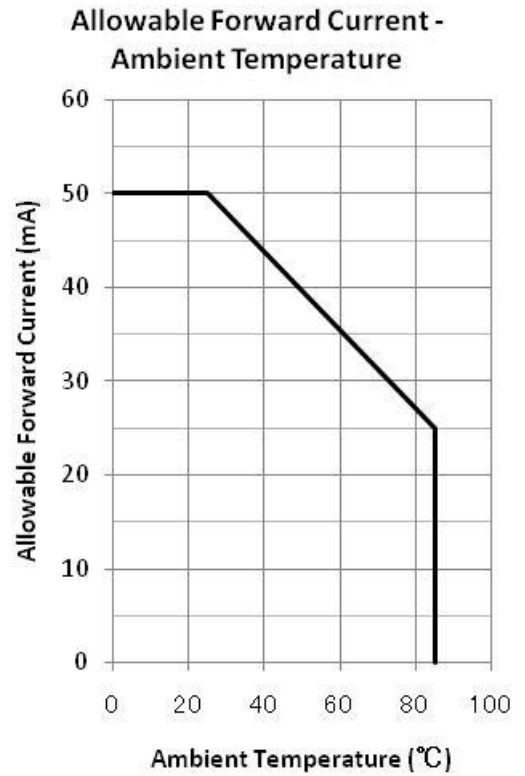
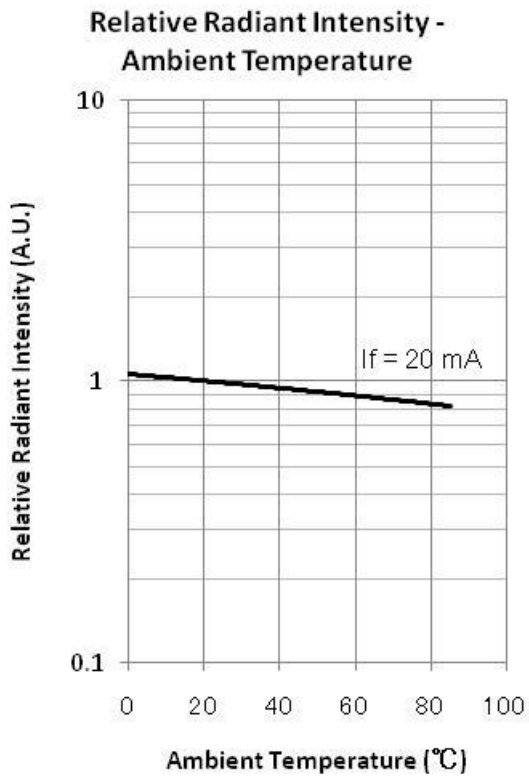

### Recommended Land Layout (unit: mm)

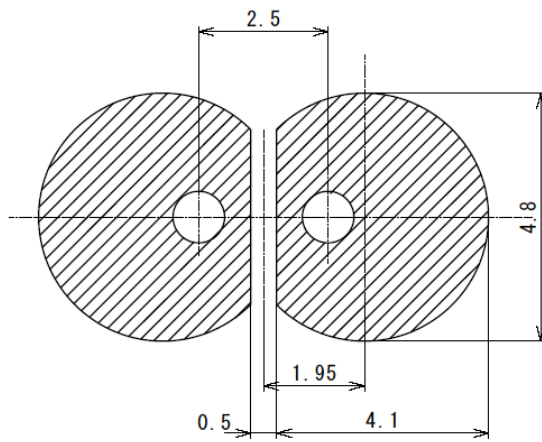

### Soldering Conditions

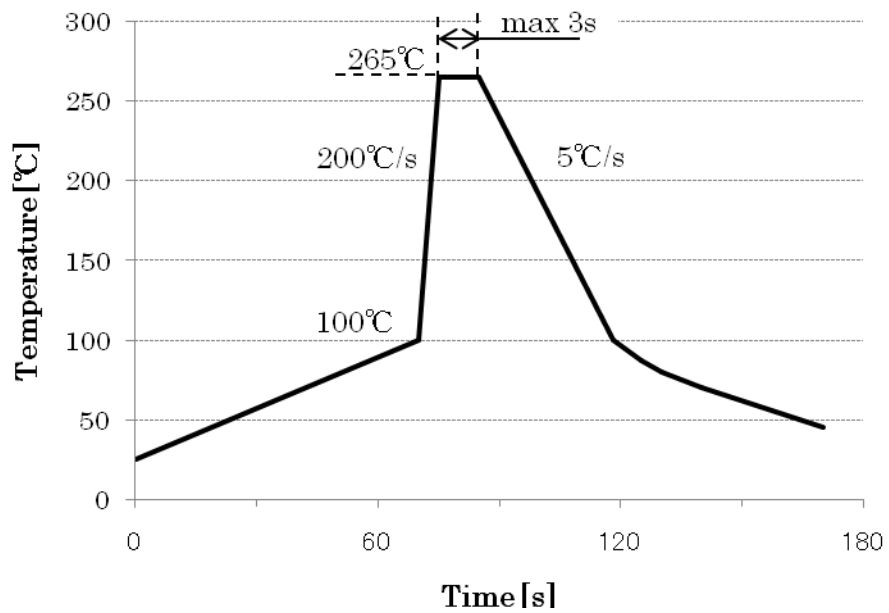

**Marubeni America Corporation**

3945 Freedom Circle, Suite 1000, Santa Clara, CA 95054 408-330-0650 (Ext. 330), 408-330-0655 (Fax), [sales@tech-led.com](mailto:sales@tech-led.com)