

L405-66-60-550 UV LED illuminator with Glass ball lens cap and heat sink

sink

L405-66-60-550 is an extremely high beam and output power illuminator assembled with a total of 60 high efficiency InGaN UV diode chips, mounted on a metal stem TO-66 and sealed with glass ball lens cap and with heat sink for high current use.

◆ Features

- 1) High beam
- 2) Compact (TO-66) package
- 3) High output power at 405nm

◆ Specifications

- 1) Product name UV Light Illuminator
- 2) Spec. No. L405-66-60-550
- 3) Chip
- (1) Material InGaN
- (2) Peak wavelength 405nm
- 4) Package
- (1) Stem TO-66 stem
- (2) Lens Glass ball lens
- (3) Heat sink Aluminum

◆ Outer dimension (Unit: mm)

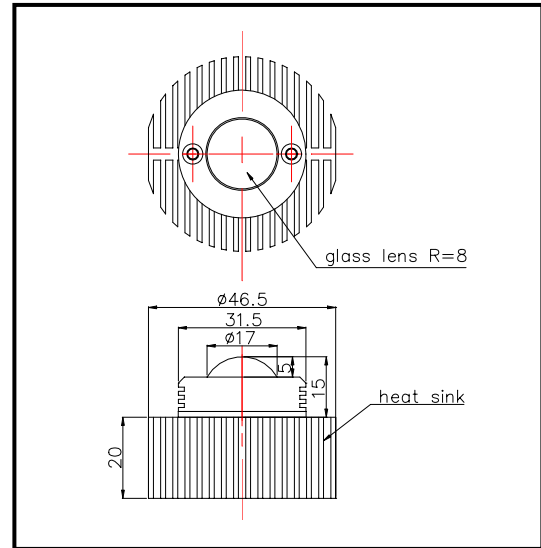

◆ Absolute Maximum Ratings

Item	Symbol	Maximum Rated Value	Unit	Ambient Temperature
Power Dissipation	P _D	6.0	W	T _a =25°C
Forward Current	I _F	300	mA	T _a =25°C
Pulse Forward Current	I _{FP}	500	mA	T _a =25°C
Reverse Voltage	V _R	30	V	T _a =25°C
Operating Temperature	T _{OPR}	-30 ~ +80	°C	
Storage Temperature	T _{STG}	-30 ~ +100	°C	
Soldering Temperature	T _{SOL}	240	°C	

‡Pulse Forward Current condition: Duty=1% and Pulse Width=1us.

‡Soldering condition : Soldering condition must be completed within 3 seconds at 260°C

◆ Electro-Optical Characteristics

Item	Symbol	Condition	Minimum	Typical	Maximum	Unit
Forward Voltage	V _F	I _F =240mA		18.0		V
Brightness	I _v	I _F =240mA		70		mcd
Total Radiated Power	P _O	I _F =240mA		300		mW
Radiant Intensity	I _E	I _F =240mA		-		mW/sr
Reverse Current	V _R	I _R =10uA	30			V
Peak Wavelength	λ _P	I _F =240mA	395	405	415	nm
Half Width	Δλ	I _F =240mA		15		nm
Viewing Half Angle	θ 1/2	I _F =240mA		±20		deg.

‡Heat sink is required thermal resistance <8K/W

‡Brightness is measured by Tektronix J-16.

‡Radiated Power is measured by Ando Optical Multi Meter AQ2140 & AQ2741