

## L395-30M32 stem type LED with ball lens

L395-30M32 is an InGaN LED mounted on TO-18 stem with ball glass lens, being designed for sensing devices.

On forward bias it emits a spectral band of radiation, which peaks at 395nm.

◆ Outer dimension (Unit:mm)

◆ Features

- 1) High Power
- 2) High Reliability

◆ Specifications

- 1) Product Name LED Lamp
- 2) Type No. L395-30M32
- 3) Chip Spec.
  - (1) Material InGaN
  - (2) Peak Wavelength 395nm
- 4) Package
  - (1) Type TO-18 stem
  - (2) Lens Ball Glass Lens

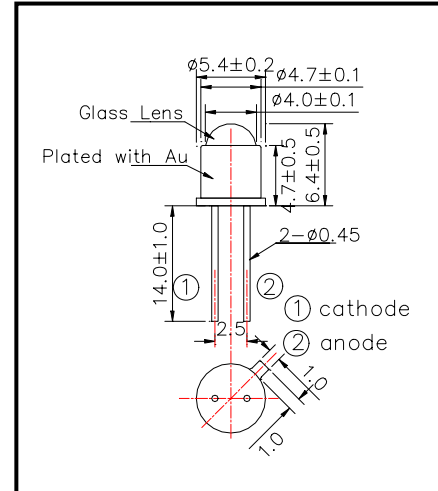

◆ Absolute Maximum Ratings

Item	Symbol	Maximum Rated Value	Unit	Ambient Temperature
Power Dissipation	PD	120	mW	Ta=25°C
Forward Current	IF	30	mA	Ta=25°C
Pulse Forward Current	IFP	100	mA	Ta=25°C
Reverse Voltage	VR	5	V	Ta=25°C
Operating Temperature	TOPR	-30 ~ +85	°C	
Storage Temperature	TSTG	-30 ~ +100	°C	
Soldering Temperature	TSOL	260	°C	

‡Pulse Forward Current condition: Duty=1% and Pulse Width=10us.

‡Soldering condition: Soldering condition must be completed within 3 seconds at 260°C

◆ Electro-Optical Characteristics

Item	Symbol	Condition	Minimum	Typical	Maximum	Unit
Forward Voltage	VF	IF=20mA		3.8	4.3	V
Reverse Current	IR	VR=5V			10	uA
Total Radiated Power	PO	IF=20mA	0.2	0.6		mW
Brightness	IV	IF=20mA		30		mcd
Radiant Intensity	IE	IF=20mA		12		mW/sr
Peak Wavelength	λP	IF=20mA	385	395	405	nm
Half Width	Δλ	IF=20mA		15		nm
Viewing Half Angle	θ 1/2	IF=20mA		±10		deg.

‡Radiated Power is measured by Ando Optical Multi Meter AQ2730 & AQ2741

‡Radiant Intensity is measured by Tektronix J-6512.