

## L395-30K42 stem type LED with unspherical lens

L395-30K42 is an InGaN LED mounted on TO-46 stem with unspherical glass lens, being designed for sensing devices.

On forward bias it emits a spectral band of radiation, which peaks at 395nm.

◆ Outer dimension (Unit:mm)

◆ Features

- 1) High Power
- 2) High Reliability

◆ Specifications

- 1) Product Name LED Lamp
- 2) Type No. L395-30K42
- 3) Chip Spec.
  - (1) Material InGaN
  - (2) Peak Wavelength 395nm
- 4) Package
  - (1) type TO-46 stem
  - (2) Lens Unspherical Glass Lens

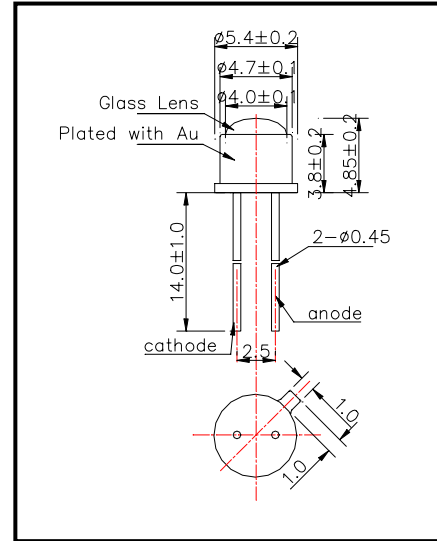

◆ Absolute Maximum Ratings

Item	Symbol	Maximum Rated Value	Unit	Ambient Temperature
Power Dissipation	P <sub>D</sub>	120	mW	T <sub>a</sub> =25°C
Forward Current	I <sub>F</sub>	30	mA	T <sub>a</sub> =25°C
Pulse Forward Current	I <sub>FP</sub>	100	mA	T <sub>a</sub> =25°C
Reverse Voltage	V <sub>R</sub>	5	V	T <sub>a</sub> =25°C
Operating Temperature	T <sub>OPR</sub>	-30 ~ +85	°C	
Storage Temperature	T <sub>STG</sub>	-30 ~ +100	°C	
Soldering Temperature	T <sub>SOL</sub>	260	°C	

‡Pulse Forward Current condition: Duty=1% and Pulse Width=10us.

‡Soldering condition: Soldering condition must be completed within 3 seconds at 260°C

◆ Electro-Optical Characteristics

Item	Symbol	Condition	Minimum	Typical	Maximum	Unit
Forward Voltage	V <sub>F</sub>	I <sub>F</sub> =20mA		3.8	4.3	V
Reverse Current	I <sub>R</sub>	V <sub>R</sub> =5V			10	uA
Total Radiated Power	P <sub>O</sub>	I <sub>F</sub> =20mA		0.4		mW
Brightness	I <sub>V</sub>	I <sub>F</sub> =20mA		45		mcd
Radiant Intensity	I <sub>E</sub>	I <sub>F</sub> =20mA		15		mW/sr
Peak Wavelength	λ <sub>P</sub>	I <sub>F</sub> =20mA	385	395	405	nm
Half Width	Δλ	I <sub>F</sub> =20mA		15		nm
Viewing Half Angle	θ <sub>1/2</sub>	I <sub>F</sub> =20mA		±6		deg.

‡Radiated Power is measured by Ando Optical Multi Meter AQ2730 & AQ2741

‡Radiant Intensity is measured by Tektronix J-6512.