

## L375-30K42L Higher beam type UVLED

L375-30K42L is an InGaN LED mounted on TO-46 stem and designed for narrow viewing angle +/-3° typ. with hermetical glass ball lens can. On forward bias it emits a spectral band of radiation, which peaks at 375nm.

### ◆Outer dimension (Unit: mm)

#### ◆Features

- 1) Narrow viewing angle
- 2) High Radiant Intensity
- 3) High Reliability

#### ◆Specifications

- 1) Product Name LED Lamp
- 2) Type No. L375-30K42L
- 3) Chip Spec.
  - (1) Material InGaN
  - (2) Peak Wavelength 375nm
- 4) Package
  - (1) Type TO-46 stem
  - (2) Lens Unspherical Ball Lens
  - (3) Cap Gold plated

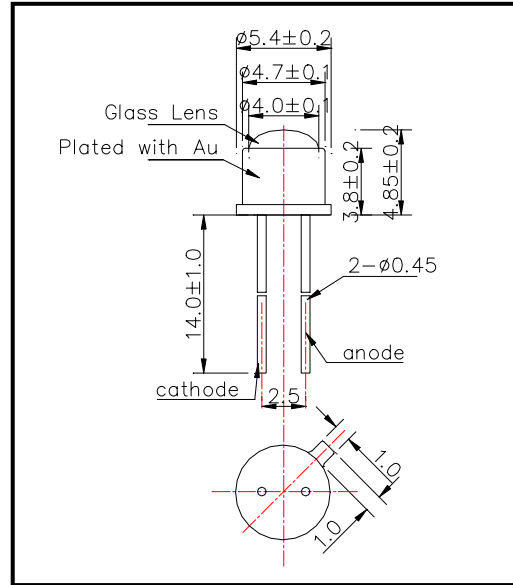

#### ◆Absolute Maximum Ratings

Item	Symbol	Maximum Rated Value	Unit	Ambient Temperature
Power Dissipation	PD	130	mW	Ta=25°C
Forward Current	IF	30	mA	Ta=25°C
Pulse Forward Current	IFP	50	mA	Ta=25°C
Reverse Voltage	VR	5	V	Ta=25°C
Operating Temperature	TOPR	-30 ~ +85	°C	
Storage Temperature	TSTG	-30 ~ +100	°C	
Soldering Temperature	TSOL	260	°C	

‡Pulse Forward Current condition: Duty=1% and Pulse Width=10us.

‡Soldering condition: Soldering condition must be completed within 3 seconds at 260°C

#### ◆Electro-Optical Characteristics

Item	Symbol	Condition	Minimum	Typical	Maximum	Unit
Forward Voltage	VF	IF=20mA		3.6	4.0	V
Reverse Current	IR	VR=5V			10	uA
Total Radiated Power	PO	IF=20mA		0.5		mW
Radiant Intensity	IE	IF=20mA		20		mW/sr
Brightness	IV	IF=20mA		-		mcd
Peak Wavelength	$\lambda_P$	IF=20mA	370	375	380	nm
Half Width	$\Delta\lambda$	IF=20mA		10		nm
Viewing Half Angle	$\theta$ 1/2	IF=20mA		$\pm 3$		°

‡Total Radiated Power is measured by Ando Optical Multi Meter AQ2140 & AQ2741.

‡Ando Optical Multi Meter AQ2140 is setted at 400nm range.

‡Radiant Intensity is measured by Epitex's designed and AQ2140 & AQ2741