

L375-30K42 stem type LED with unspherical lens

L375-30K42 is an InGaN LED mounted on TO-46 stem with unspherical glass lens, being designed for sensing devices.

On forward bias it emits a spectral band of radiation, which peaks at 375nm.

◆ Outer dimension (Unit:mm)

◆ Features

- 1) High Power
- 2) High Reliability

◆ Specifications

- 1) Product Name LED Lamp
- 2) Type No. L375-30K42
- 3) Chip Spec.
 - (1) Material InGaN
 - (2) Peak Wavelength 375nm
- 4) Package
 - (1) type TO-46 stem
 - (2) Lens Unspherical Glass Lens

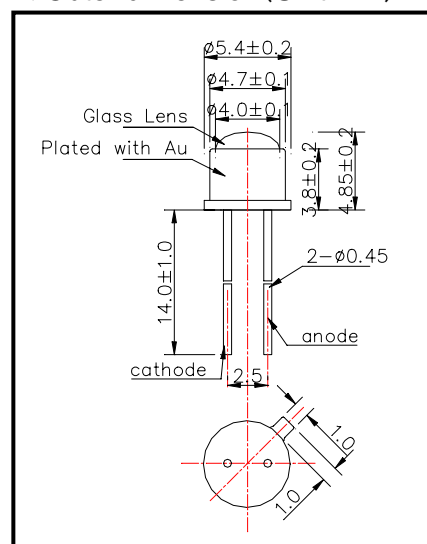

◆ Absolute Maximum Ratings

Item	Symbol	Maximum Rated Value	Unit	Ambient Temperature
Power Dissipation	P _D	110	mW	T _a =25°C
Forward Current	I _F	30	mA	T _a =25°C
Pulse Forward Current	I _{FP}	100	mA	T _a =25°C
Reverse Voltage	V _R	5	V	T _a =25°C
Operating Temperature	T _{OPR}	-30 ~ +85	°C	
Storage Temperature	T _{STG}	-30 ~ +100	°C	
Soldering Temperature	T _{SOL}	260	°C	

‡ Pulse Forward Current condition: Duty=1% and Pulse Width=10us.

‡ Soldering condition: Soldering condition must be completed within 3 seconds at 260°C

◆ Electro-Optical Characteristics

Item	Symbol	Condition	Minimum	Typical	Maximum	Unit
Forward Voltage	V _F	I _F =20mA		3.5	4.0	V
Reverse Current	I _R	V _R =5V			10	uA
Total Radiated Power	P _O	I _F =20mA	0.20	0.40		mW
Brightness	I _V	I _F =20mA		10		mcd
Radiant Intensity	I _E	I _F =20mA		1.4		mW/sr
Peak Wavelength	λ _P	I _F =20mA	370	375	380	nm
Half Width	Δλ	I _F =20mA		20		nm
Viewing Half Angle	θ _{1/2}	I _F =20mA		±6		deg.

‡ Radiated Power is measured by Ando Optical Multi Meter AQ2730 & AQ2741

‡ Radiant Intensity is measured by Tektronix J-6512.