

L370-30M32 stem type LED with ball lens

L370-30M32 is an InGaN LED mounted on TO-18 stem with ball glass lens, being designed for sensing devices.

On forward bias it emits a spectral band of radiation, which peaks at 370nm.

◆ Features

- 1) High Power
- 2) High Reliability

◆ Specifications

- | | |
|---------------------|-----------------|
| 1) Product Name | LED Lamp |
| 2) Type No. | L370-30M32 |
| 3) Chip Spec. | |
| (1) Material | InGaN |
| (2) Peak Wavelength | 370nm |
| 4) Package | |
| (1) Type | TO-18 stem |
| (2) Lens | Ball Glass Lens |

◆ Outer dimension (Unit:mm)

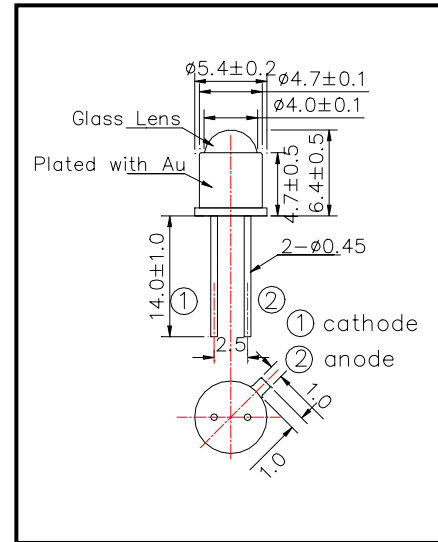

◆ Absolute Maximum Ratings

Item	Symbol	Maximum Rated Value	Unit	Ambient Temperature
Power Dissipation	P _D	110	mW	T _a =25°C
Forward Current	I _F	30	mA	T _a =25°C
Pulse Forward Current	I _{FP}	100	mA	T _a =25°C
Reverse Voltage	V _R	5	V	T _a =25°C
Operating Temperature	T _{OPR}	-30 ~ +85	°C	
Storage Temperature	T _{STG}	-30 ~ +100	°C	
Soldering Temperature	T _{SOL}	260	°C	

‡Pulse Forward Current condition: Duty=1% and Pulse Width=10us.

‡Soldering condition: Soldering condition must be completed within 3 seconds at 260°C

◆ Electro-Optical Characteristics

Item	Symbol	Condition	Minimum	Typical	Maximum	Unit
Forward Voltage	V _F	I _F =20mA		3.5	4.0	V
Reverse Current	I _R	V _R =5V			10	uA
Total Radiated Power	P _O	I _F =20mA	0.25	0.6		mW
Brightness	I _V	I _F =20mA		5		mcd
Radiant Intensity	I _E	I _F =20mA		1.0		mW/sr
Peak Wavelength	λ _P	I _F =20mA	360	370	380	nm
Half Width	Δλ	I _F =20mA		20		nm
Viewing Half Angle	θ _{1/2}	I _F =20mA		±10		deg.

‡Radiated Power is measured by Ando Optical Multi Meter AQ2730 & AQ2741

‡Radiant Intensity is measured by Tektronix J-6512.