

# L1450-\_\_ \_\_

## Infrared LED Lamp

This series of L1300-\_\_ \_\_ is an InGaAsP LED mounted on a lead frame and encapsulated in various types of epoxy lens which offer different design settings.

On forward bias, it emits a high power radiation of typical 2.5mW with a peak wavelength at 1450nm.

### Specifications

- |                    |             |
|--------------------|-------------|
| 1. Chip material   | InGaAsP     |
| 2. Peak wavelength | 1450nm      |
| 3. Resin Material  | Epoxy resin |
| 4. Solder          | Lead free   |



### Absolute Maximum Ratings

Item	Symbol	Maximum Rated Value	Unit	Ambient Temperature
Power Dissipation	$P_D$	140	mW	$T_a=25^{\circ}\text{C}$
Forward Current	$I_F$	100	mA	$T_a=25^{\circ}\text{C}$
Pulse Forward Current	$I_{FP}$	1000	mA	$T_a=25^{\circ}\text{C}$
Reverse Voltage	$V_R$	5	V	$T_a=25^{\circ}\text{C}$
Operating Temperature	$T_{OPR}$	-30 ~ +85	$^{\circ}\text{C}$	
Storage Temperature	$T_{STG}$	-40 ~ +100	$^{\circ}\text{C}$	
Soldering Temperature	$T_{SOL}$	265	$^{\circ}\text{C}$	

### Electro-Optical Characteristics ( $T_a=25^{\circ}\text{C}$ )

Item	Symbol	Condition	Minimum	Typical	Maximum	Unit
Forward Voltage	$V_F$	$I_F=50\text{mA}$		1.0	1.5	V
Reverse Current	$I_R$	$V_R=5\text{V}$			10	$\mu\text{A}$
Radiated Power	$P_O$	$I_F=50\text{mA}$	1.3	2.5		mW
Peak Wavelength	$\lambda_P$	$I_F=50\text{mA}$	1400	1450	1500	nm
Half Width	$\Delta\lambda$	$I_F=50\text{mA}$		100		nm
Rise Time	$t_r$	$I_F=50\text{mA}$		10		ns
Fall Time	$t_f$	$I_F=50\text{mA}$		10		ns

**Characteristics of Radiant Intensity (Ta=25°C)**

Type	Viewing Half Angle	Radiant Intensity I <sub>F</sub> =50mA Unit : mW/sr			Outer Dimension	Dimension Figure
		Minimum	Typical	Maximum		
L1450-01					Φ5	1
L1450-02					Φ5	2
L1450-03	±10°		18		Φ5	3
L1450-04					Φ5	4
L1450-05					Φ5	5
L1450-06	±7°		32		Φ5	6
L1450-09					Φ5 Oval	7
L1450-46					Φ5	8
L1450-41					Φ4	9
L1450-42					Φ4	10
L1450-31					Φ3	11
L1450-33	±18°		9		Φ3	12
L1450-34					Φ3	13
L1450-36	±33°		3		Φ3	14

Radiant Power is measured by G8370-85

Brightness is measured by Tektronix J-16

**Marubeni America Corporation**

3945 Freedom Circle, Suite 1000, Santa Clara, CA 95054 408-330-0650 (Ext. 330), 408-330-0655 (Fax), [sales@tech-led.com](mailto:sales@tech-led.com)

**Outer Dimension of LED Lamp**

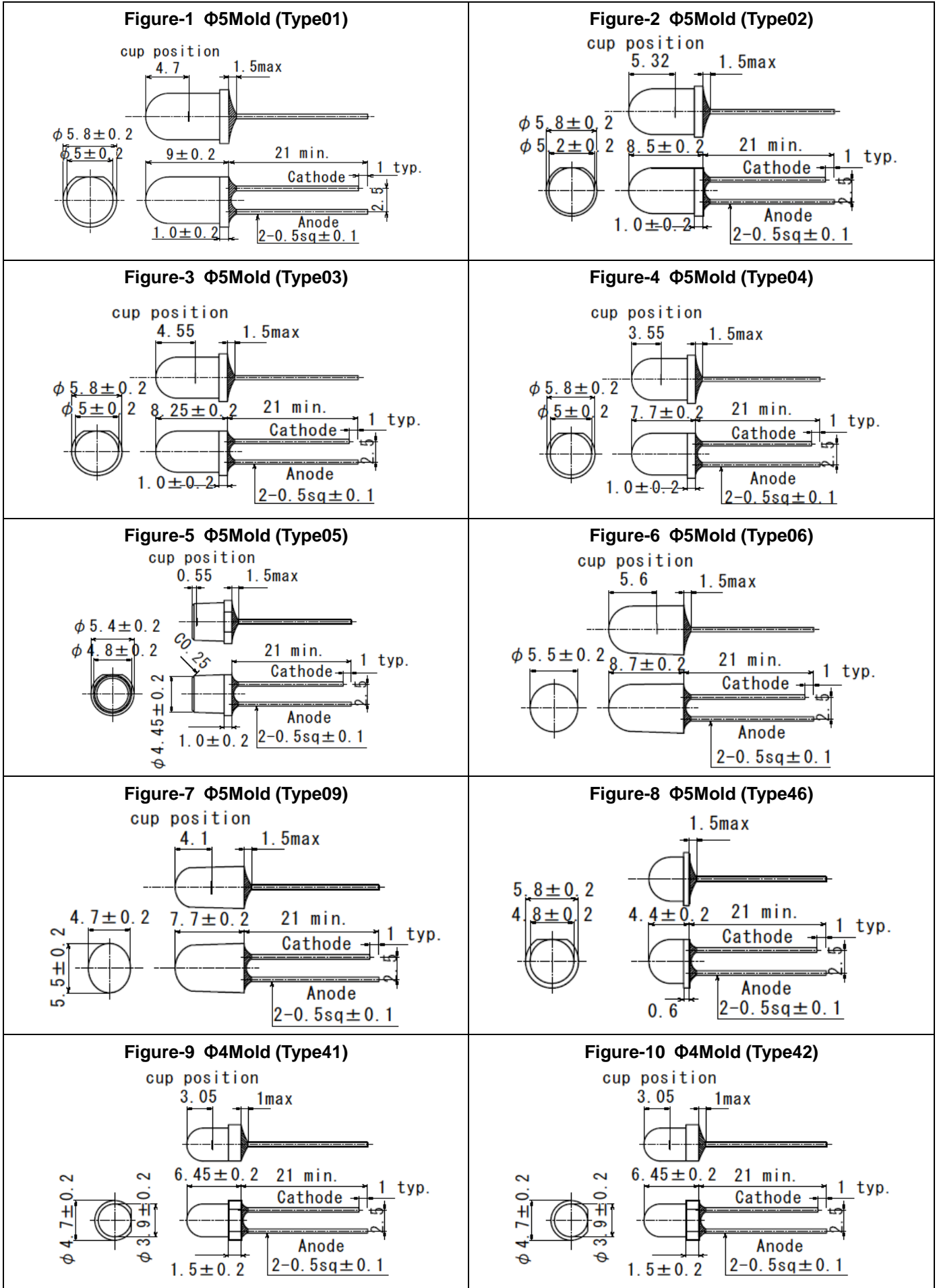

**Marubeni America Corporation**

3945 Freedom Circle, Suite 1000, Santa Clara, CA 95054 408-330-0650 (Ext. 330), 408-330-0655 (Fax), [sales@tech-led.com](mailto:sales@tech-led.com)

**Outer Dimension of LED Lamp**

<p><b>Figure-11 <math>\Phi 3</math>Mold (Type31)</b> cup position</p> <p>0.37 1max  <math>\phi 3.6 \pm 0.2</math>  <math>\phi 3 \pm 0.2</math>  <math>3.5 \pm 0.2</math> 21 min.      Cathode 1 typ.      Anode      1.5 typ. <math>2-0.5sq \pm 0.1</math></p>	<p><b>Figure-12 <math>\Phi 3</math>Mold (Type33)</b> cup position</p> <p>2.65 1max  <math>\phi 3.8 \pm 0.2</math>  <math>\phi 3 \pm 0.2</math>      5.3 21 min.      Cathode 1 typ.      Anode      0.8 typ. <math>2-0.5sq \pm 0.1</math></p>
<p><b>Figure-13 <math>\Phi 3</math>Mold (Type34)</b> cup position</p> <p>3.25 1max  <math>\phi 3.8 \pm 0.2</math>  <math>\phi 3 \pm 0.2</math>  <math>5.3 \pm 0.2</math> 21 min.      Cathode 1 typ.      Anode      1.5 typ. <math>2-0.5sq \pm 0.1</math></p>	<p><b>Figure-14 <math>\Phi 3</math>Mold (Type36)</b> cup position</p> <p>2.1 1max  <math>\phi 4 \pm 0.2</math>  <math>\phi 3 \pm 0.2</math>  <math>5.3 \pm 0.2</math> 21 min.      Cathode 1 typ.      Anode  <math>2 \pm 0.4</math> <math>2-0.5sq \pm 0.1</math></p>
<p><b>Figure-15</b></p>	<p><b>Figure-16</b></p>
<p><b>Figure-17</b></p>	<p><b>Figure-18</b></p>
<p><b>Figure-19</b></p>	<p><b>Figure-20</b></p>

The Viewing half angle

Figure-1  $\Phi 5$ Mold (Type01)

Figure-2  $\Phi 5$ Mold (Type02)

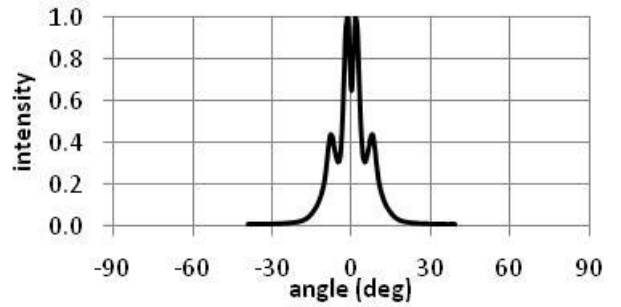

Figure-3  $\Phi 5$ Mold (Type03)

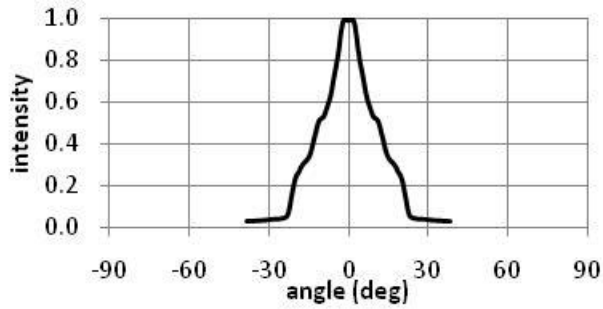

Figure-4  $\Phi 5$ Mold (Type04)

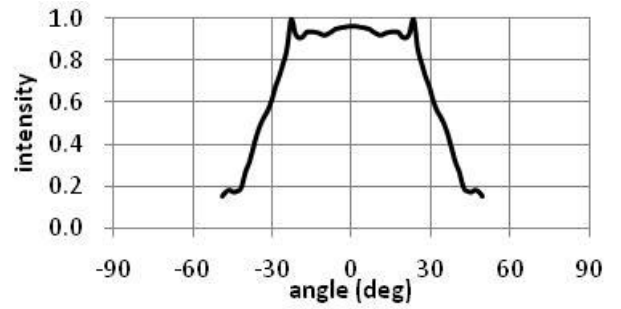

Figure-5  $\Phi 5$ Mold (Type05)

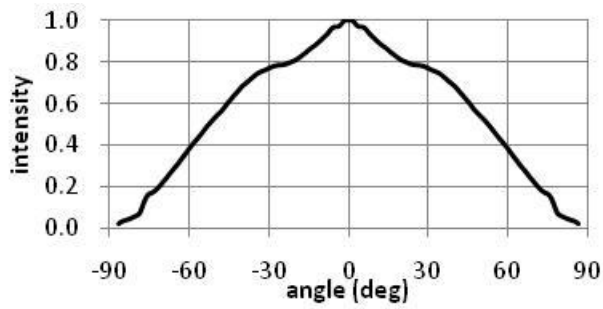

Figure-6  $\Phi 5$ Mold (Type06)

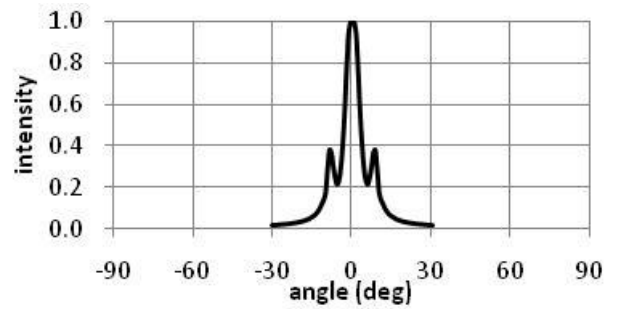

Figure-7  $\Phi 5$ Mold (Type09)

Figure-8  $\Phi 5$ Mold (Type46)

Figure-9  $\Phi 4$ Mold (Type41)

Figure-10  $\Phi 4$ Mold (Type42)

The Viewing half angle

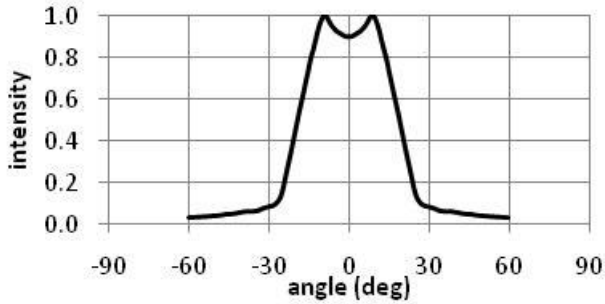
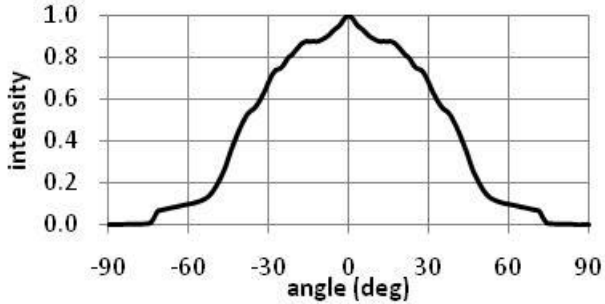
<p>Figure-11 <math>\Phi</math>3Mold (Type31)</p>	<p>Figure-12 <math>\Phi</math>3Mold (Type33)</p> 
<p>Figure-13 <math>\Phi</math>3Mold (Type34)</p>	<p>Figure-14 <math>\Phi</math>3Mold (Type36)</p> 
<p>Figure-15</p>	<p>Figure-16</p>
<p>Figure-17</p>	<p>Figure-18</p>
<p>Figure-19</p>	<p>Figure-20</p>

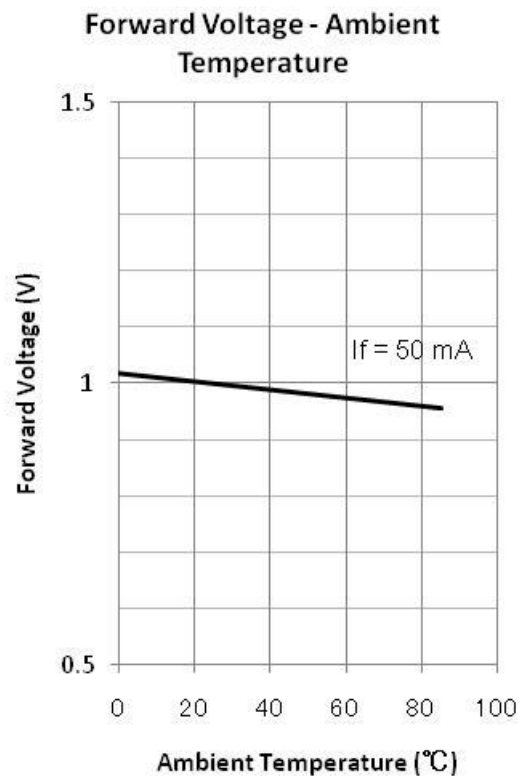
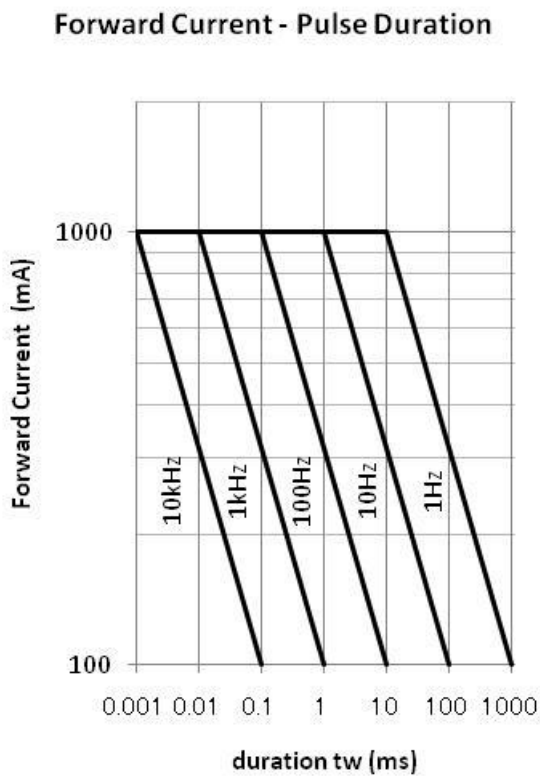
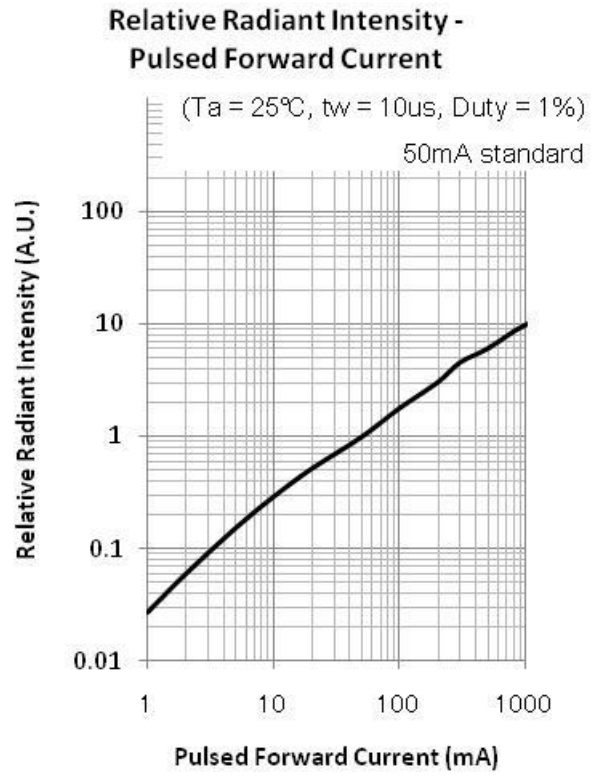
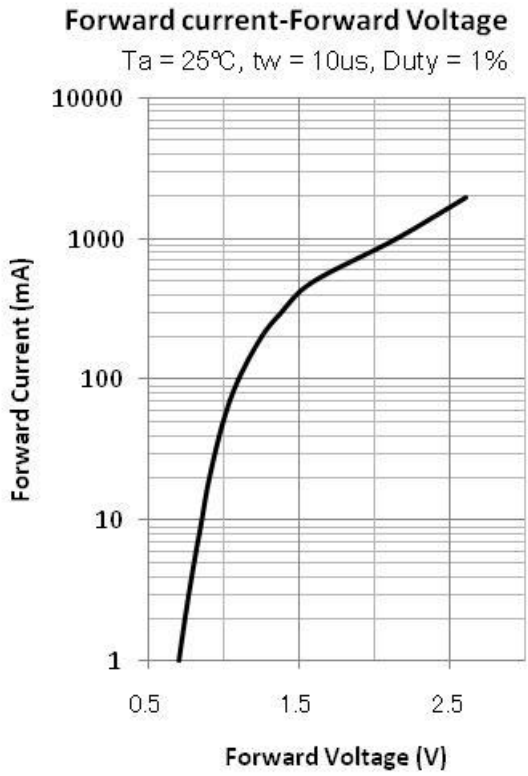

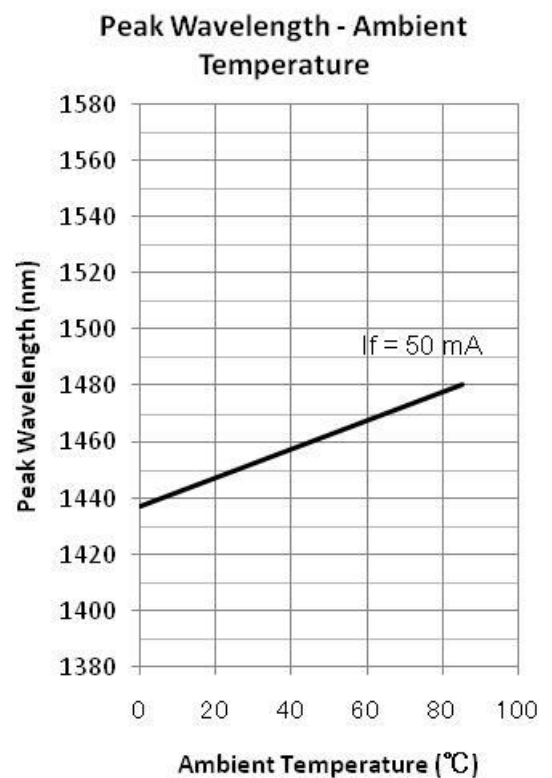
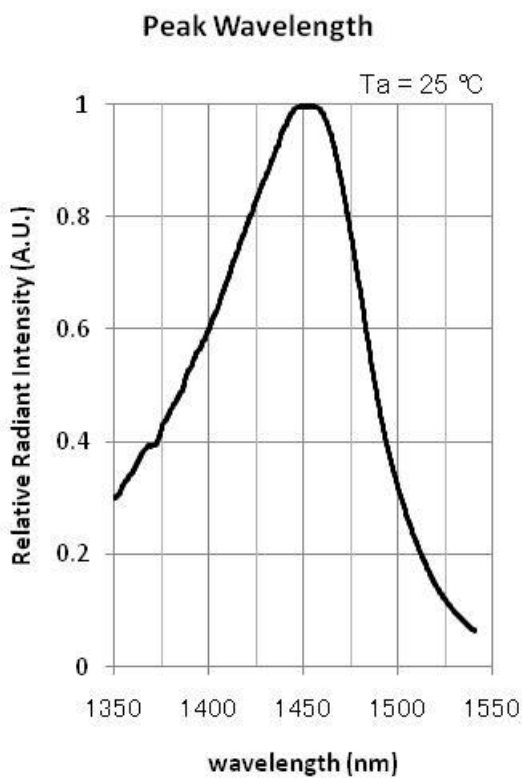
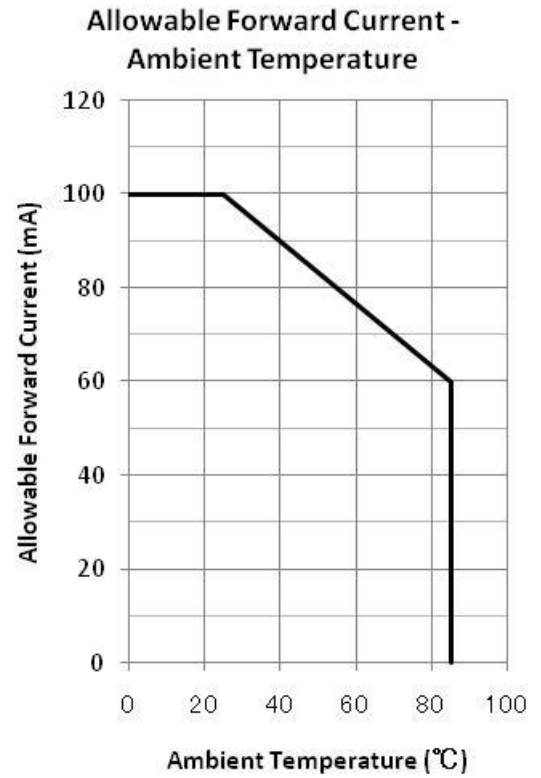
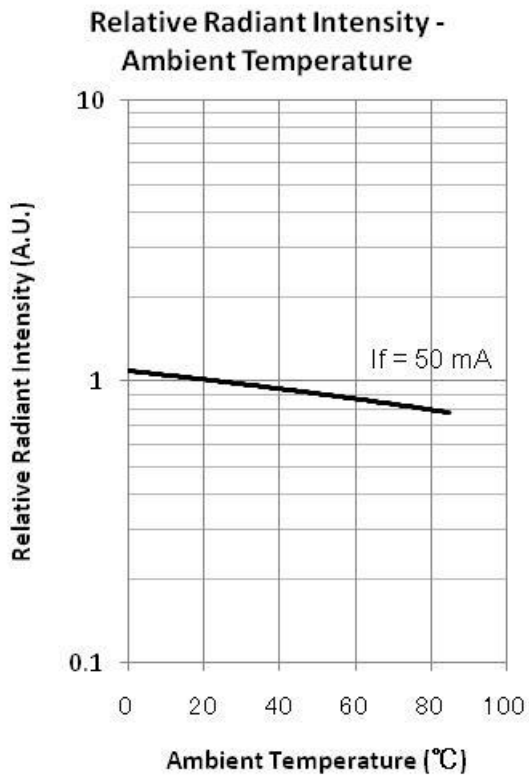

**Marubeni America Corporation**

3945 Freedom Circle, Suite 1000, Santa Clara, CA 95054 408-330-0650 (Ext. 330), 408-330-0655 (Fax), [sales@tech-led.com](mailto:sales@tech-led.com)

**Recommended Land Layout (unit: mm)**

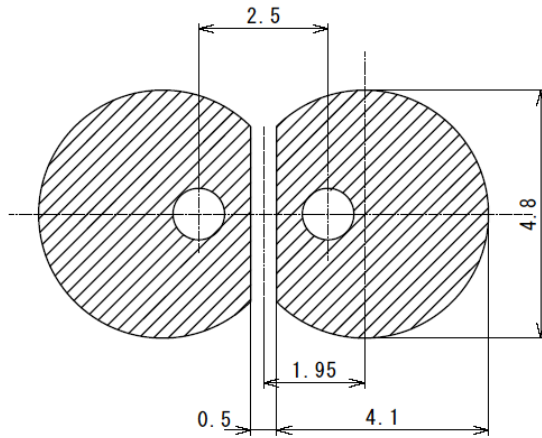

**Soldering Conditions**

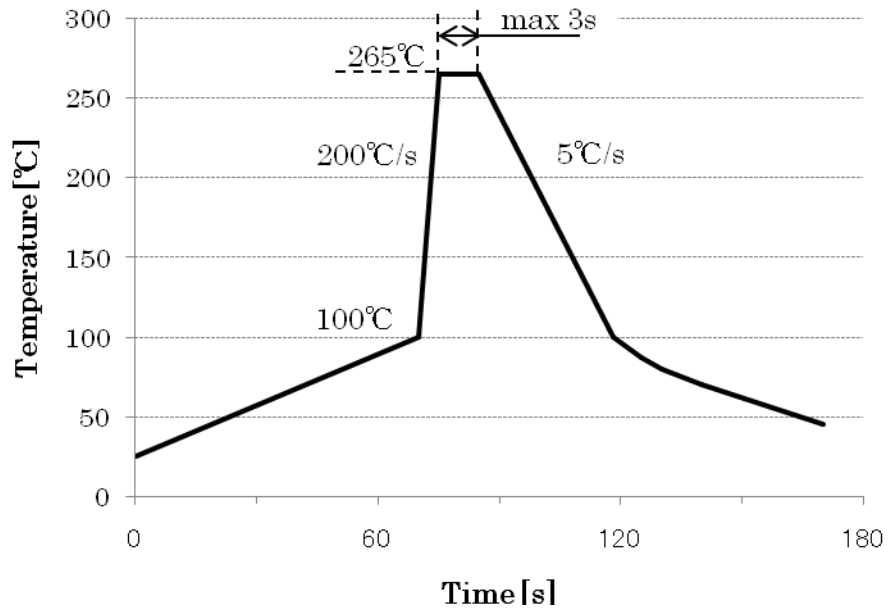

**Marubeni America Corporation**

3945 Freedom Circle, Suite 1000, Santa Clara, CA 95054 408-330-0650 (Ext. 330), 408-330-0655 (Fax), [sales@tech-led.com](mailto:sales@tech-led.com)