

SPECIFICATION OF LED CHIP C940-55P [INFRARED]

1) Commodity Type and Physical Characteristics.

- | | | | |
|----------------------|-------------|------------------|------------|
| 1. Material | GaAlAs/GaAs | | |
| 2. Electrode | Top Side | P (anode) side | : Au Alloy |
| | Bottom Side | N (cathode) side | : Au Alloy |
| 3. Electrode Pattern | Fig.1 | | |
| 4. Chip Size | Fig.2 | | |
| 5. Chip Thickness | Fig.2 | | |
| 6. Emission Area | Fig.2 | | |

2) Electro-Optical Characteristics

Parameters	Symbol	Condition	min.	typ.	max.	unit
Forward Voltage	V _f	I _f =20mA		1.15	1.25	V
Forward Voltage	V _f	I _f =50mA		1.23	1.35	
Reverse Current	I _r	V _r =5V			10	uA
Power Intensity	P _o	I _f =20mA	2.0	3.5		mW
Peak Wavelength	λ _P	I _f =20mA	930	940	955	nm
Spectral Radiation Bandwidth	Δλ	I _f =20mA		50		nm
RiseTime	t _r	I _f =20mA		1000		ns
FallTime	t _f	I _f =20mA		500		ns

‡ Die shall be mounted on TO=18 gold header without resin coated.(T_a=25°C)

[Unit : um]

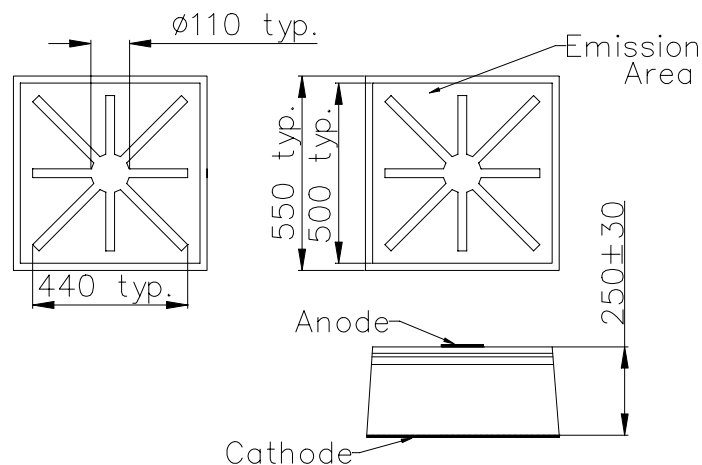

Fig.1 Electrode Pattern

Fig.2 Chip size and Emission Area